

Biorefinery

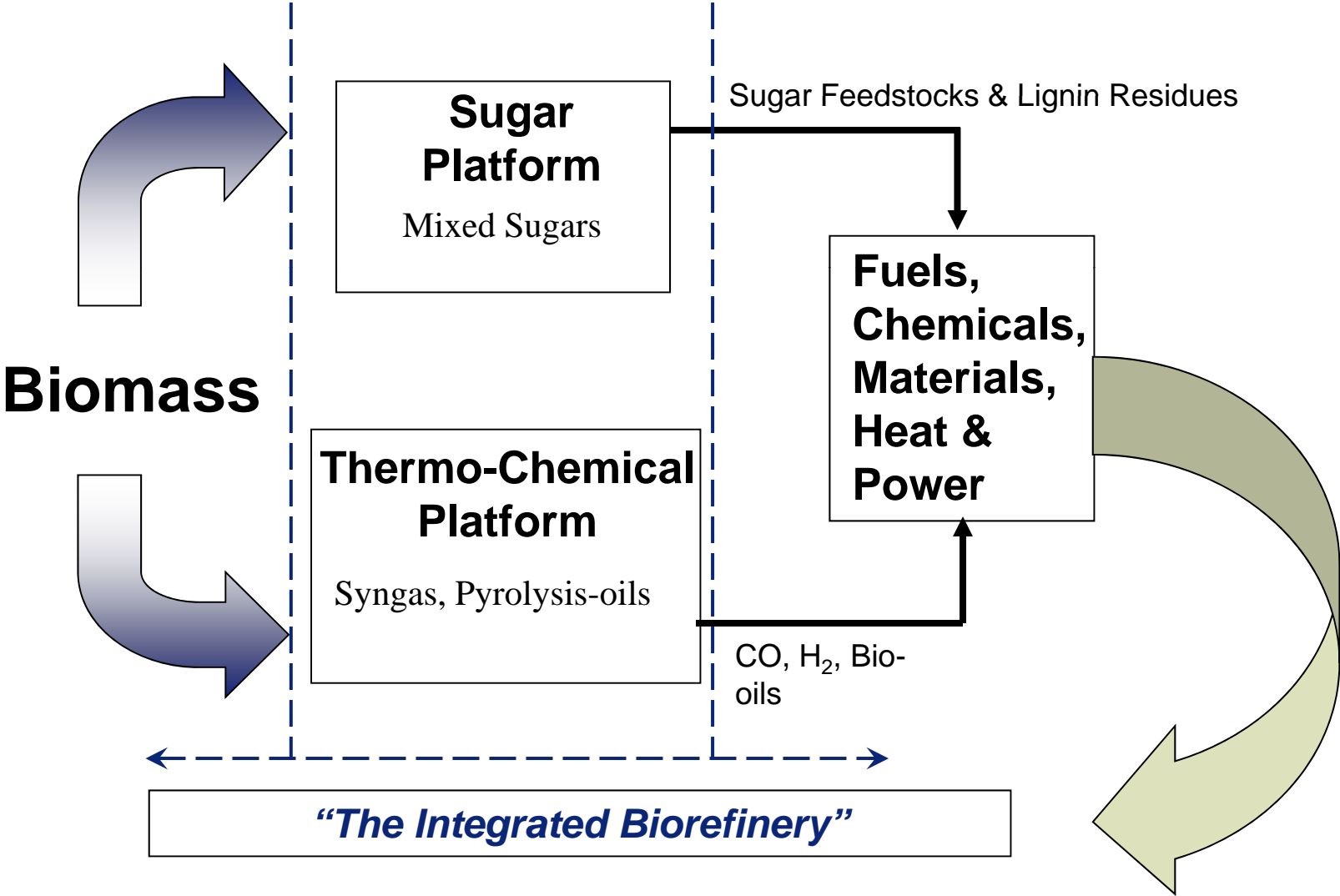

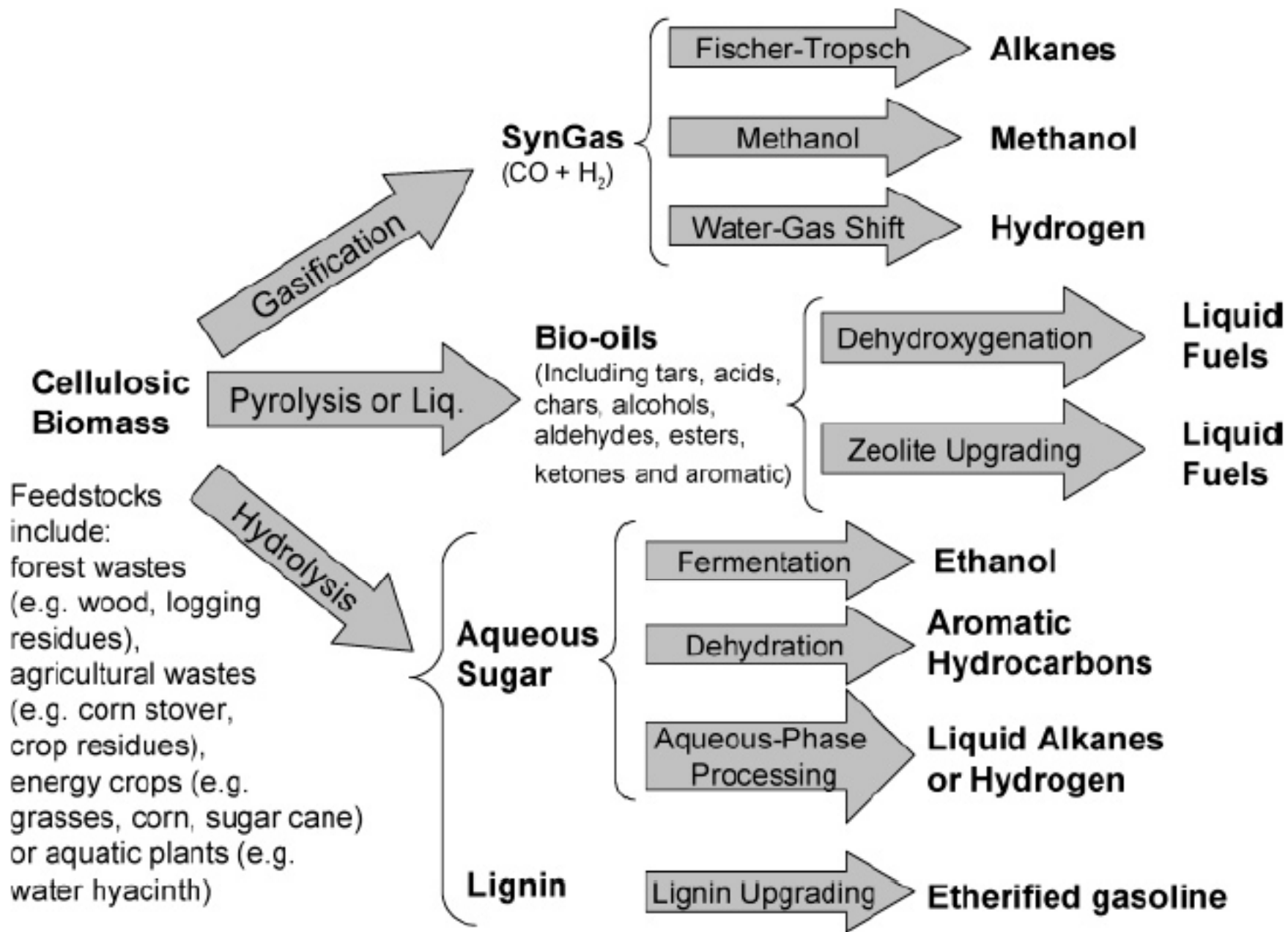

Platform chemicals: cellulose

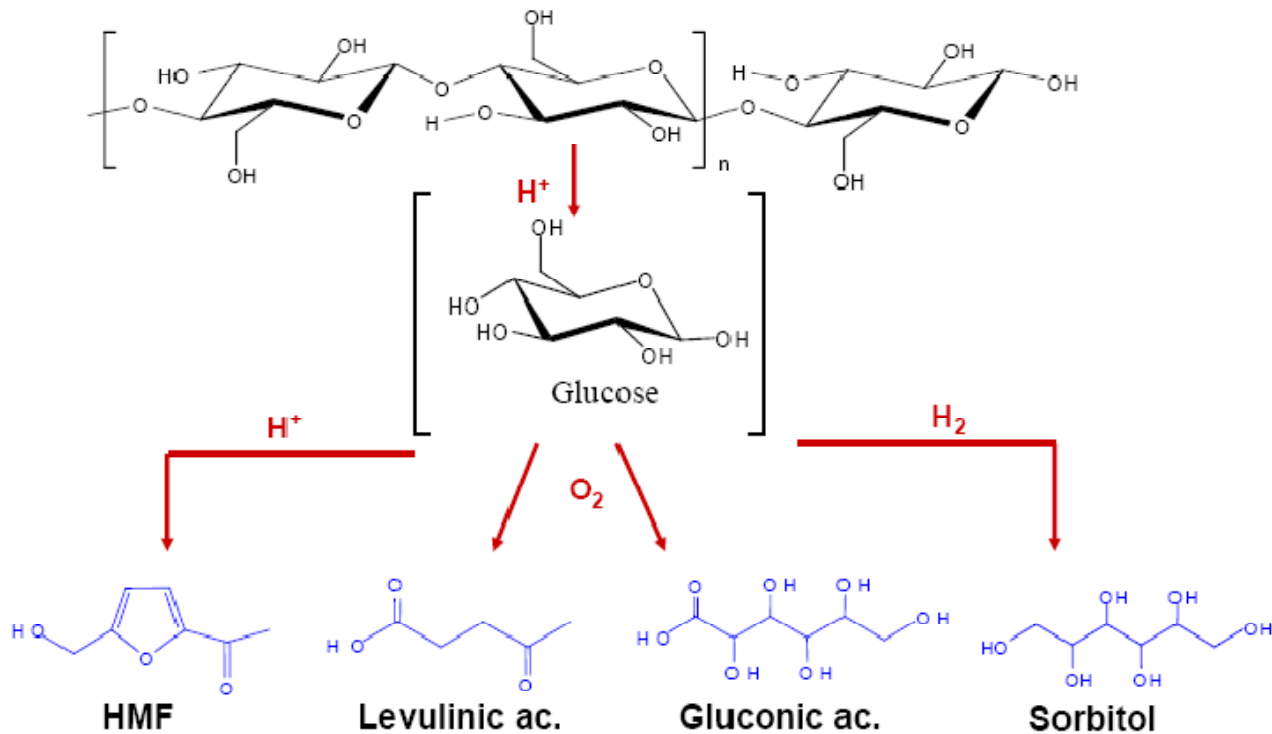

Levulinic acid

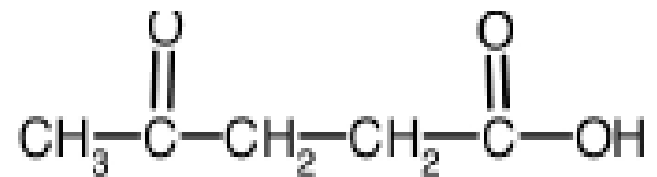

di Serena Fugalli

Le Calorie Srl - Caserta. fugalliserena@msn.com

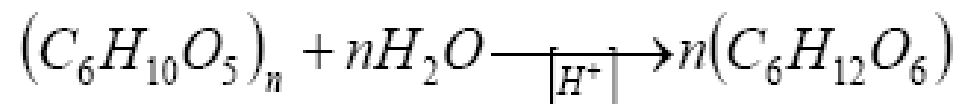

cellulosa + acqua → glucosio

(in presenza di acido)

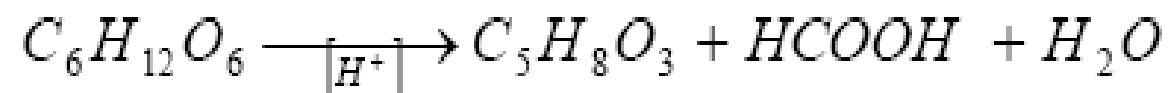

glucosio → acido levulinico + acido formico + acqua

Levulinic acid



Hydrolysis reactor

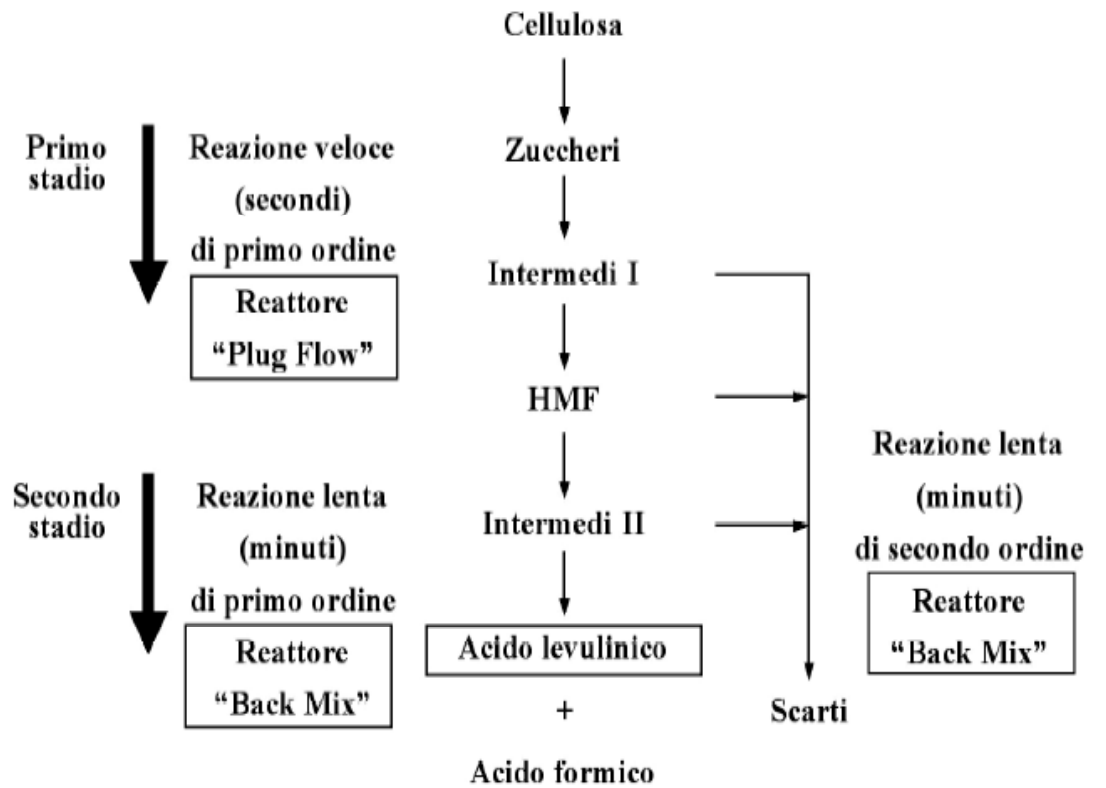

Enzymatic cellulose hydrolysis

3 types of enzyme activity required

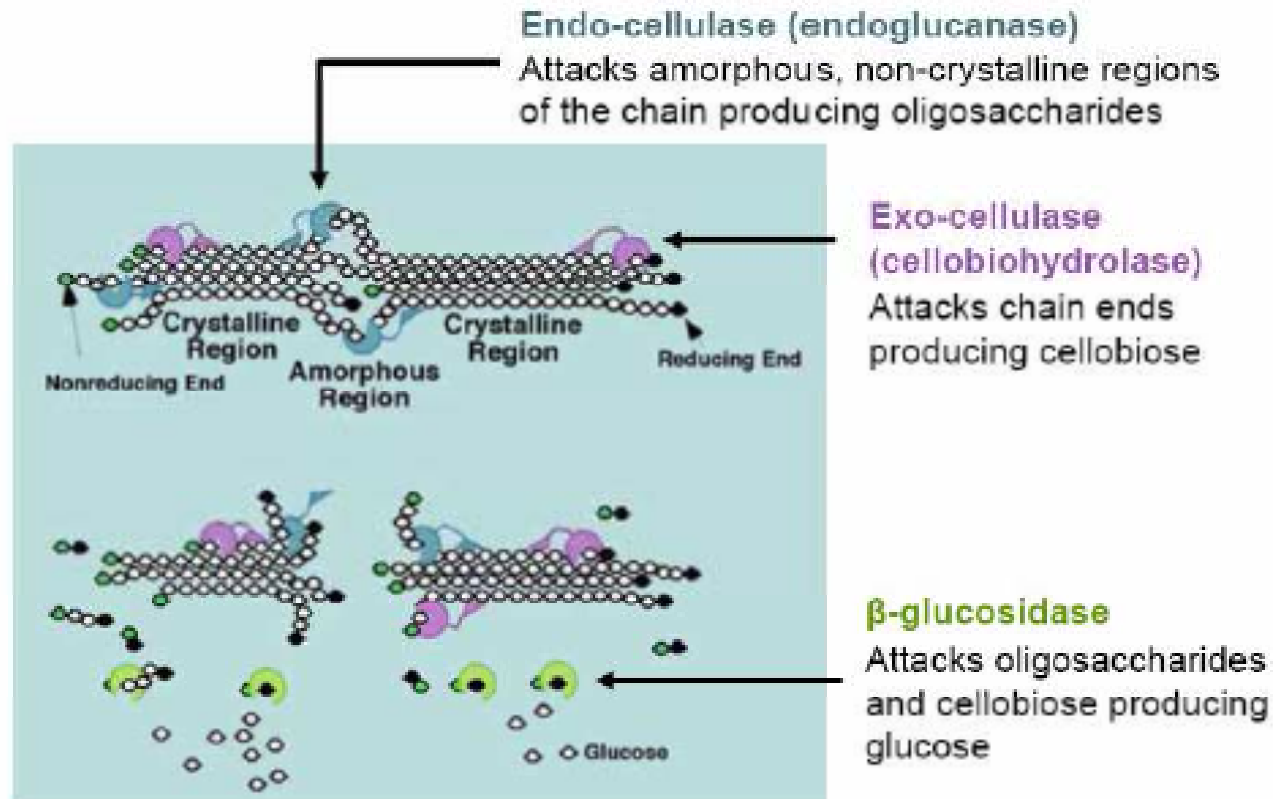

Source: Kevin A. Gray Ph. D. , 2007. Conversion of lignocellulosic biomass into liquid transportation fuels Diversa Corporation/Celunol, San Diego, CA , USA. <http://www.epobio.net/workshop0705/presentations/KevinGray.pdf>

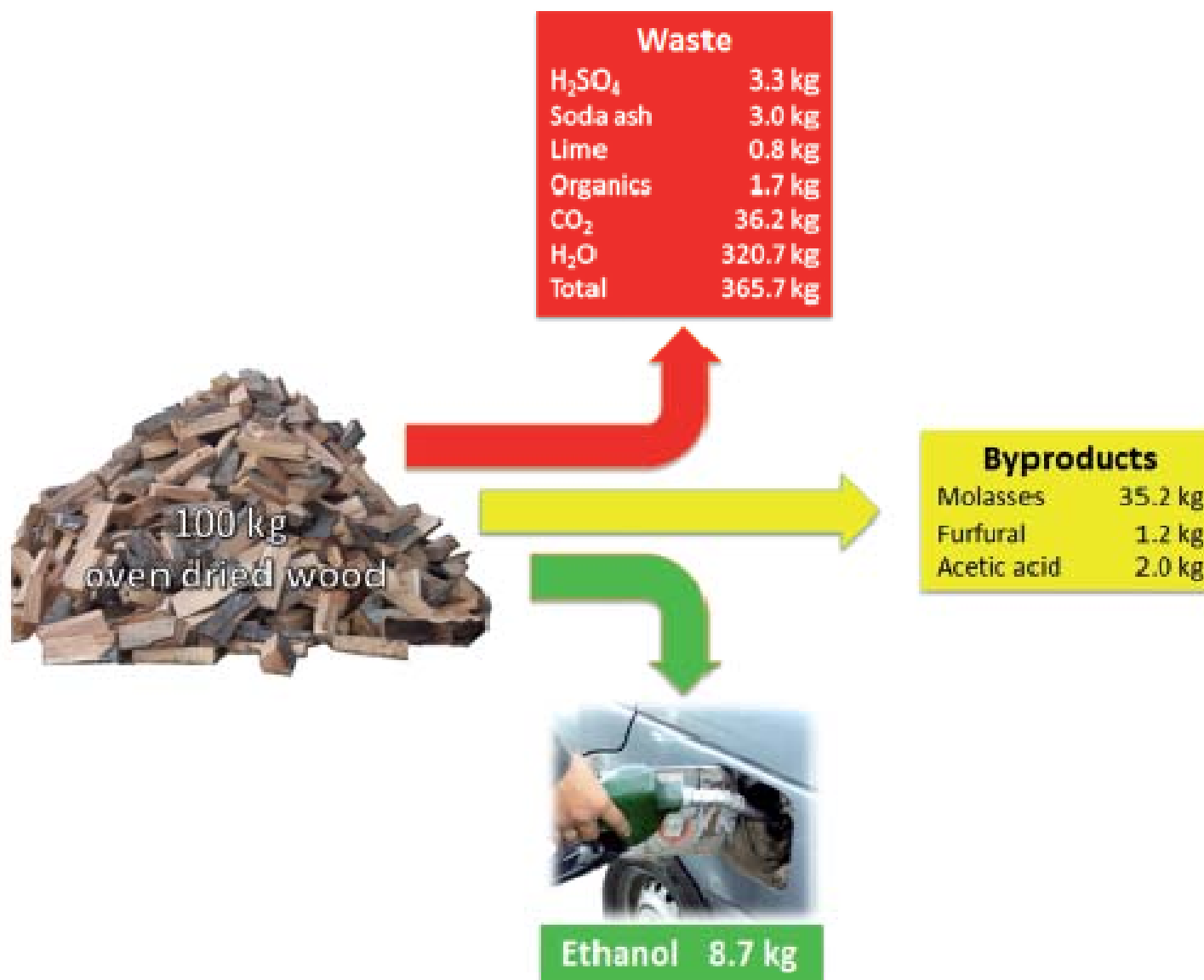

E-factor
 40.2 kg waste per kg ethanol

Corn vs Wood?

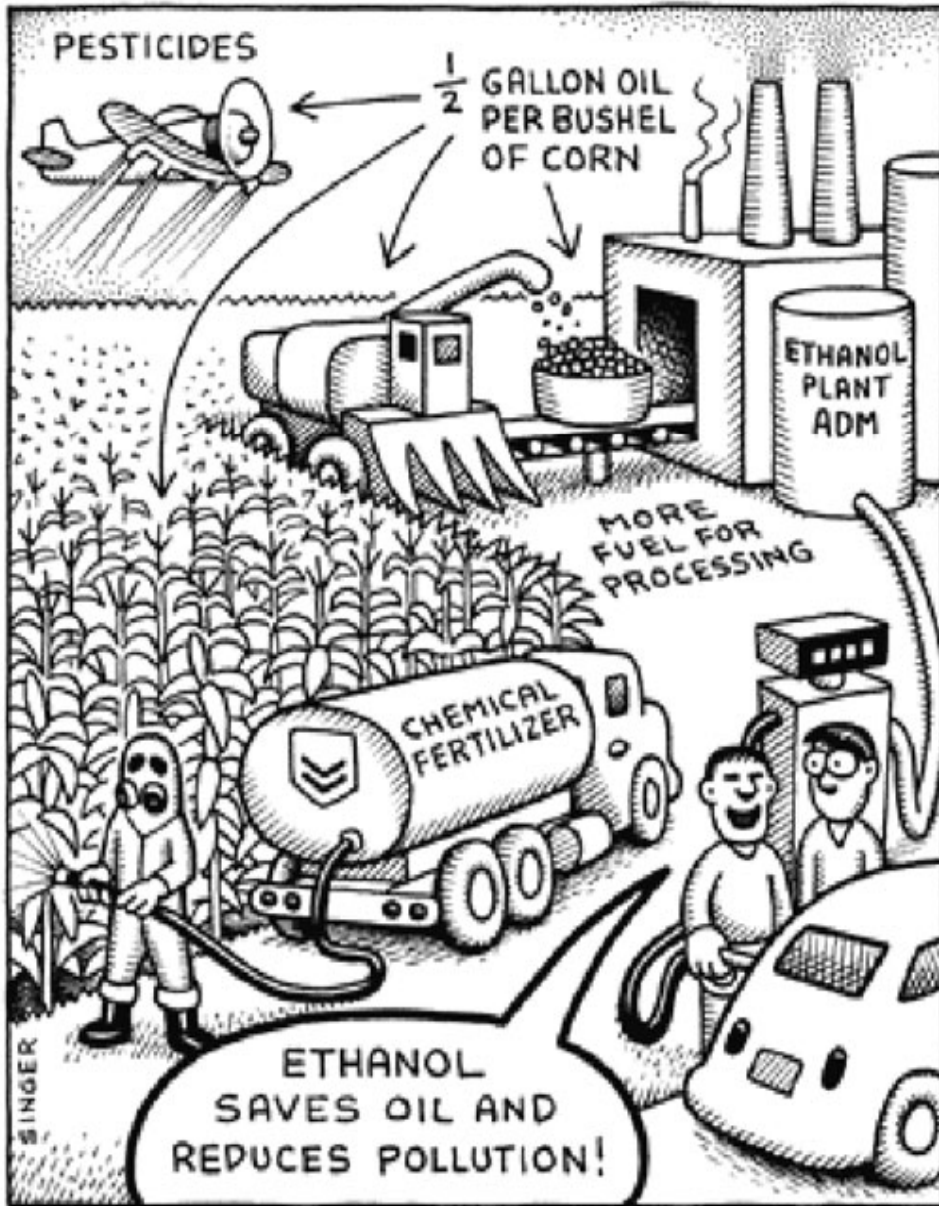

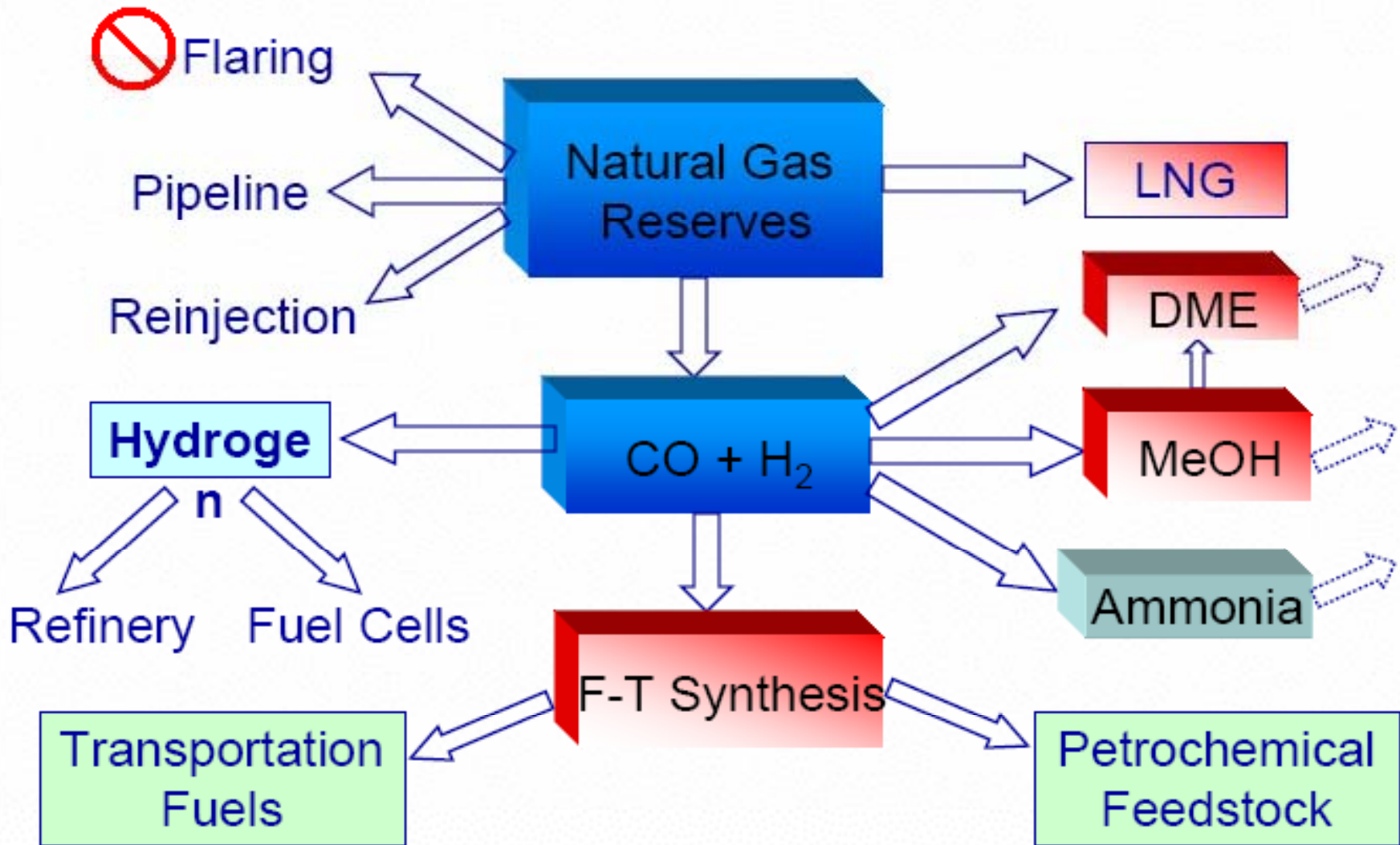

Conversion Routes to Synthesis Gas

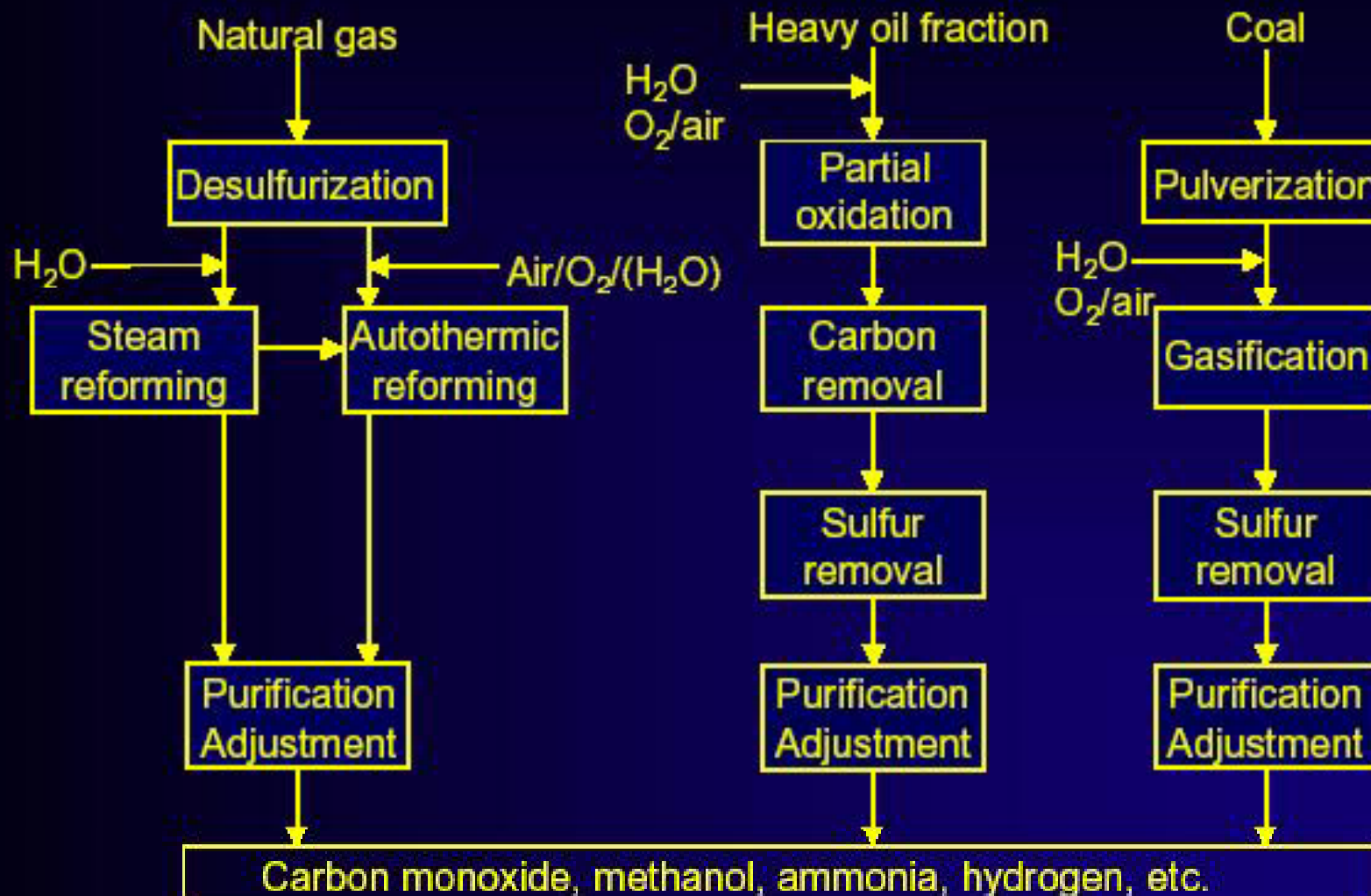

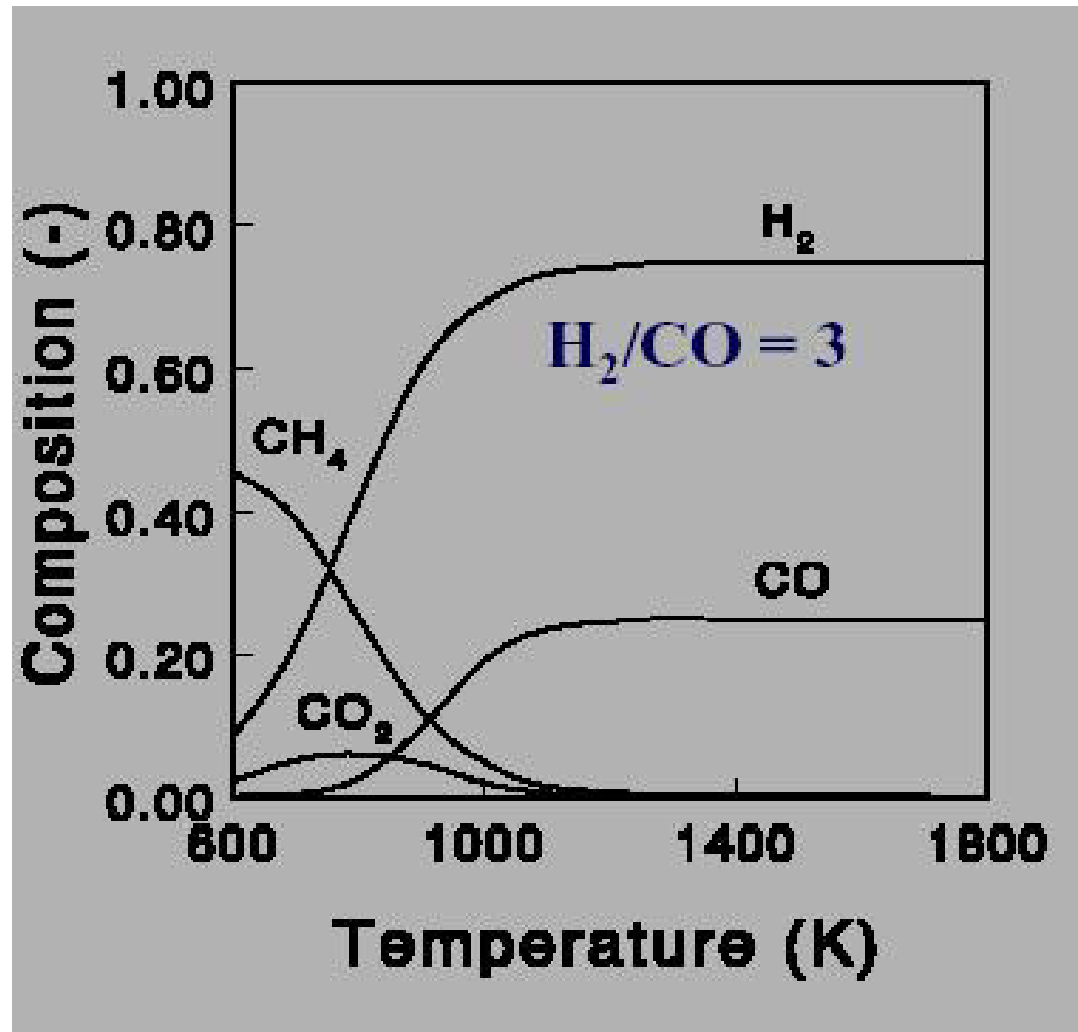

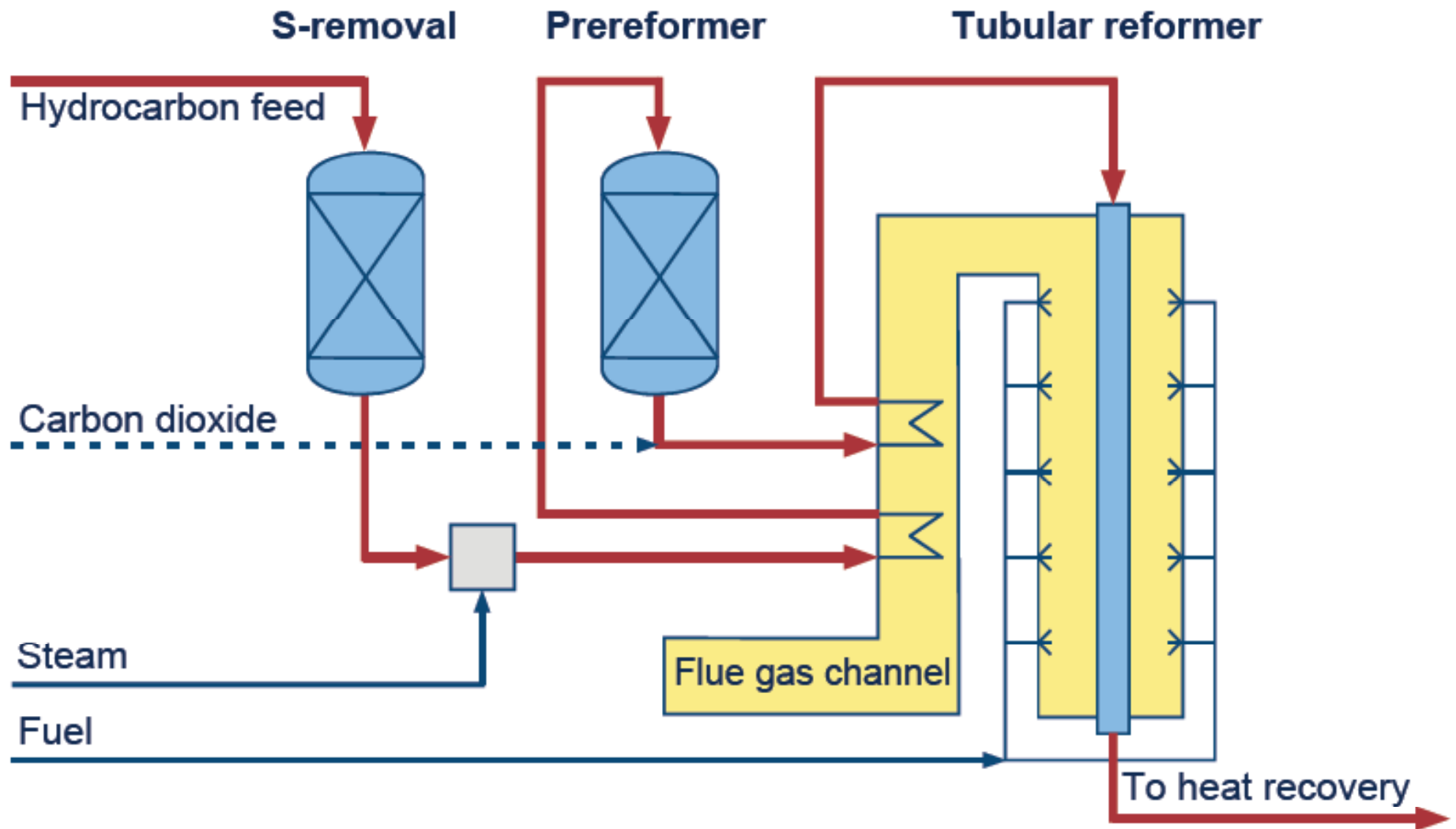

- Adiabatic vessel with highly active nickel catalyst
- Converts higher hydrocarbons
- Allows higher preheat temperatures to tubular reformer or ATR
- Reduces size of tubular reformer
- Reduces oxygen consumption in ATR-based plant.

Prereformer



Tubes (500-600) filled with catalyst
 $L=7-12$ m, $d=70-130$ mm

Autothermal Reforming

Why O₂, not air?

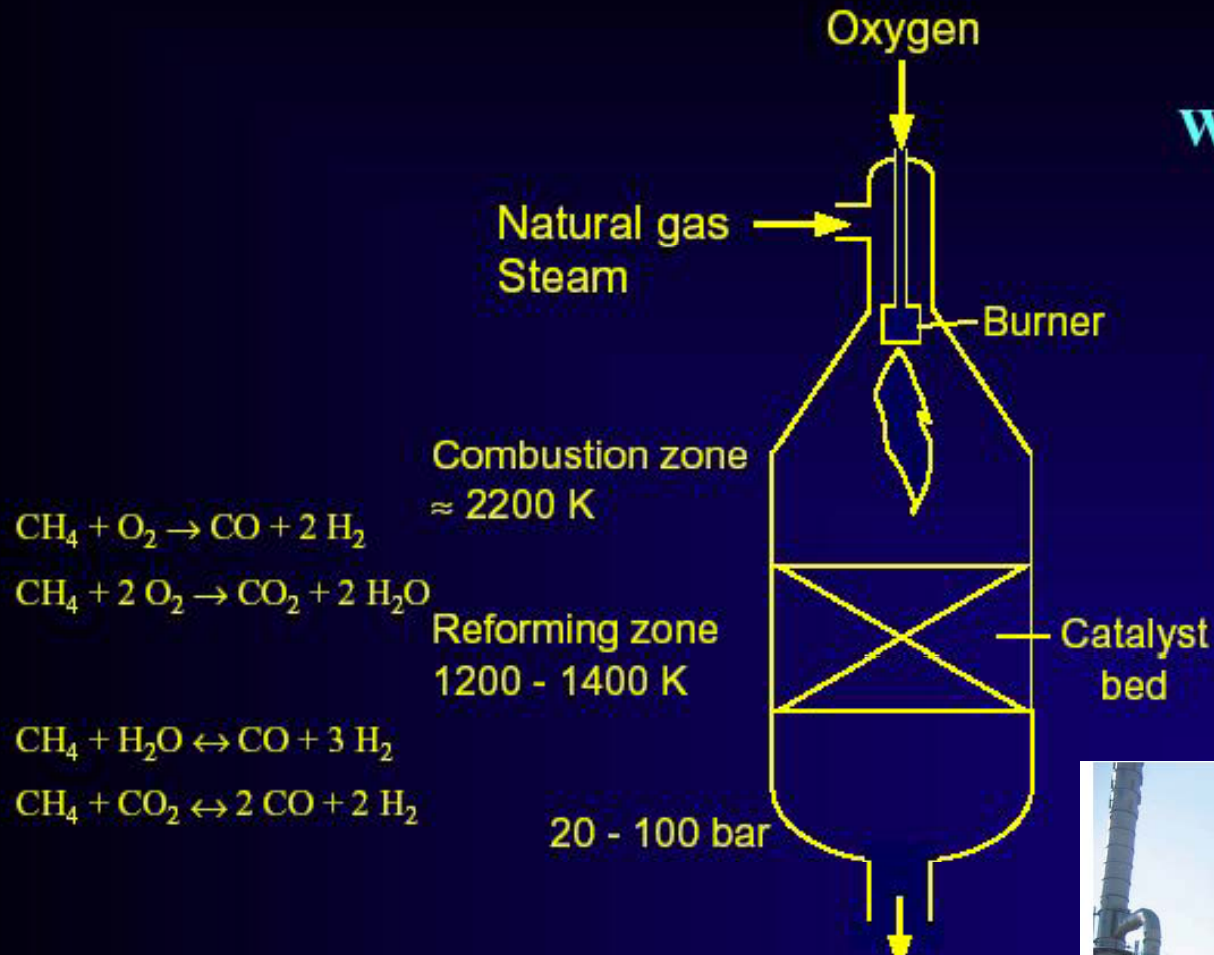

Molar feed ratio:

H₂O/CH₄: 1 - 2

O₂/CH₄: ≈ 0.6



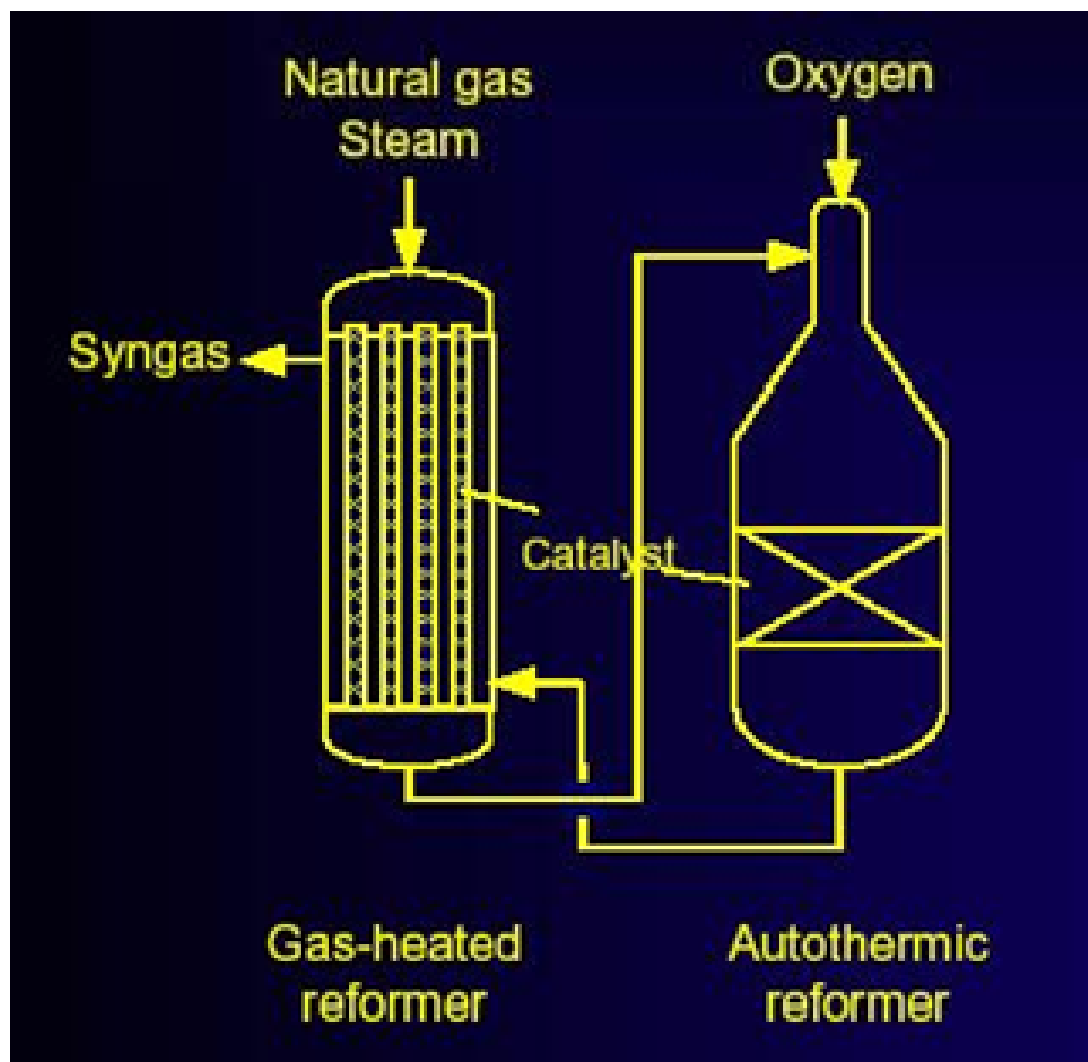

Gasification

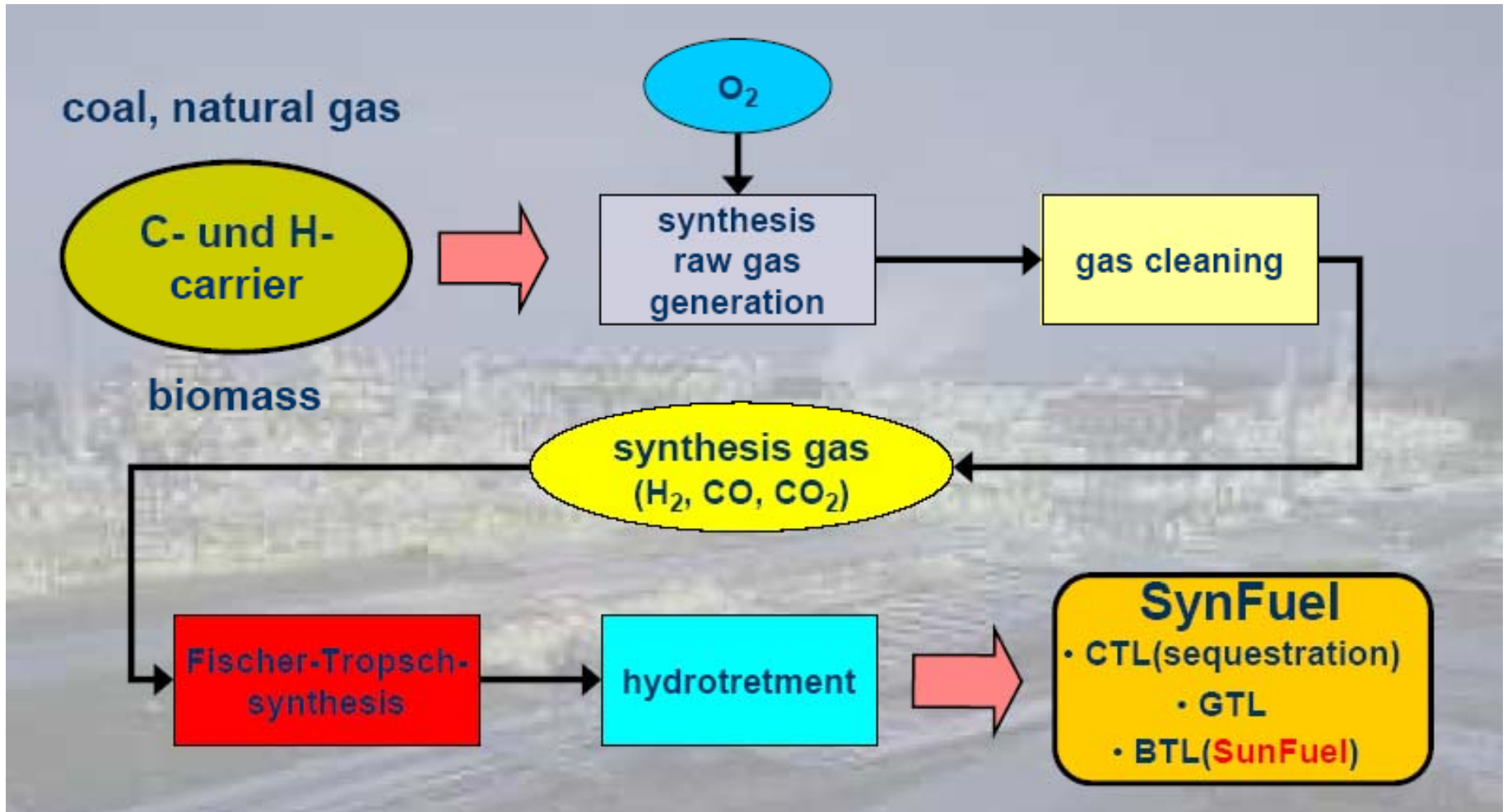

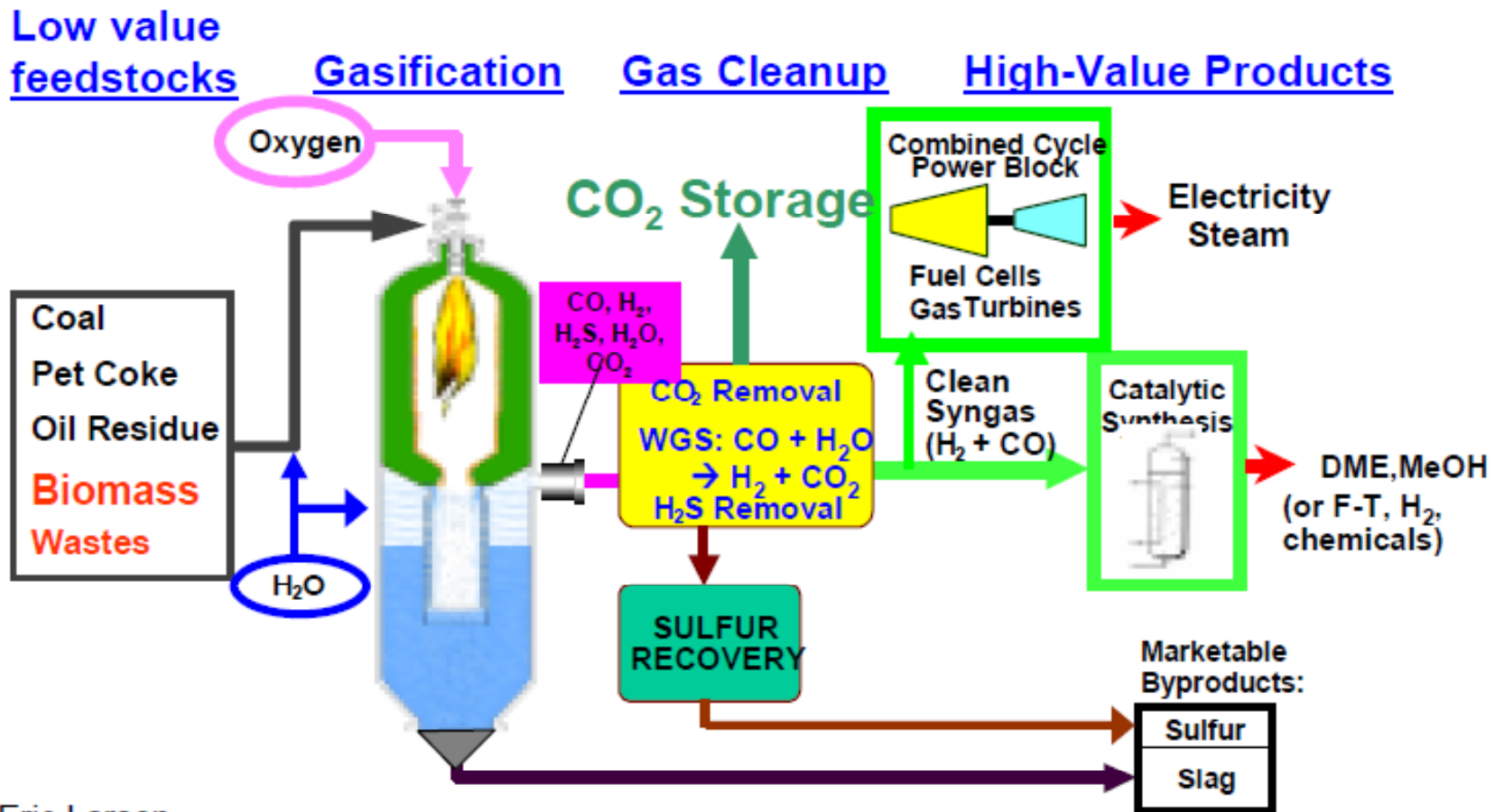

Source: Eric Larson

- ➔ Gasification is key technology for making clean fuels from coal or biomass and for low-cost CO₂ capture & storage

Fischer-Tropsch Reaction

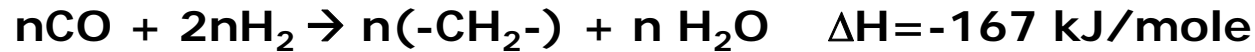

Main features of modern GTL-FT:

- Low temperature (200-240°C) and mid pressure (20-30 bar) to promote F-T over methanation reaction
- Active catalyst based on **IRON** or **COBALT**
- Production of high molecular weight linear waxes for further hydroprocessing step to optimize the overall liquid production, because it is impossible to produce directly a well defined range of products (i.e. middle distillates)

Fischer-Tropsch

Goal: production of liquid fuels or chemicals from gas

Also called: GTL

- political reasons (South Africa)
- remote gas fields (e.g., SMDS)

Main reactions

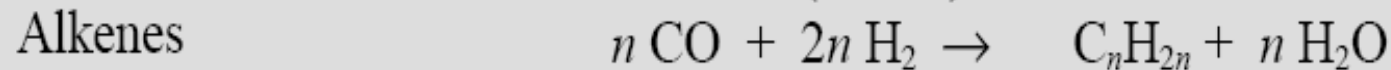
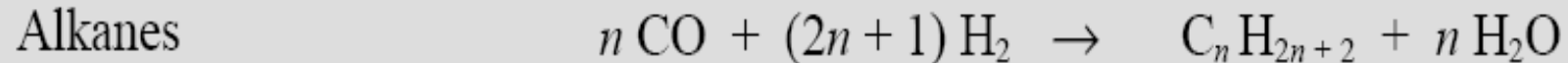

Side reactions

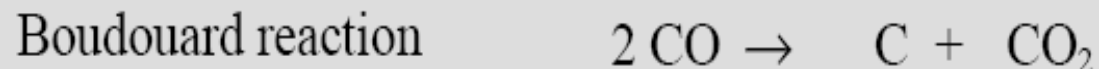
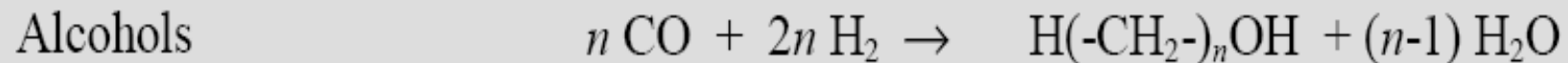

Franz Fischer (1877-1947)



**Professor Dr. Franz Fischer, Geh. Reg.-Rat
(Direktor des Instituts von der Gründung bis heute)**

Hans Tropsch (1889-1935)



Dr.-Ing. Hans Tropsch,
Abteilungsleiter von 1921—1928
(am Institut tätig von 1916—1917 und 1921—1928)

01653

CHEMISCHE WERKE ESSENER STEINKOHLE A.G., Bergkamen

Geheim
Staatsgeheim
sein, bei Post-
übertragung
Verantwortung des
hervor Verschleiß.

Patentanmeldung C 55 917 IV d/12 o vom 27. November 1941.

Verfahren zur Herstellung höherer Kohlenwasserstoffe
durch katalytische Hydrierung von Oxyden des Kohlen-
stoffs.

- Basic F-T reaction



- Stoichiometric H_2/CO ratio = 2

- Products predominantly normal paraffins, but may contain significant quantities of α -olefins and/or alcohols:



Fischer-Tropsch

- Hans Fischer and Franz Tropsch discovered the chemistry in 1923
- Germany commercialized the technology in WWII
- Today the future is bright

SASOL

- 160,000 b/d+
- Feedstock - Coal



Petro SA

- 22,500 b/d+
- Feedstock - Natural Gas



Shell

- 15,000 b/d+
- Feedstock - Natural Gas



Sasol Oryx Project

- 34,000 b/d
- Feedstock - Natural Gas
- Online 2006



Gas-to-Liquids (FT) Process

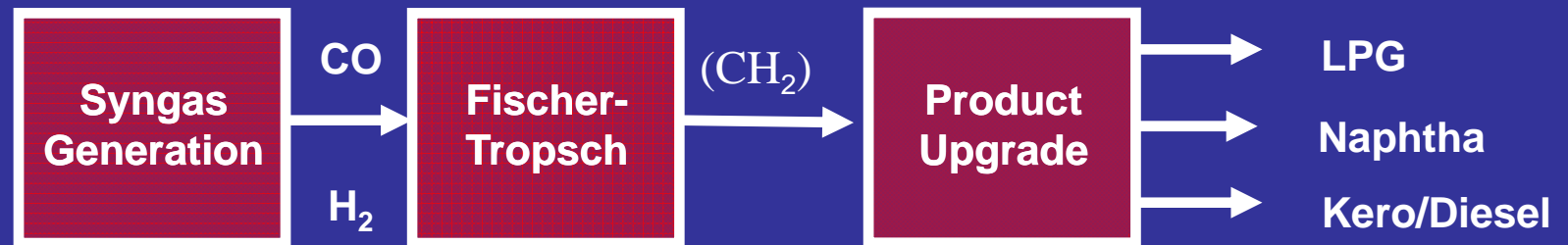

Technology – *FT Process*

Technical challenges

- Catalyst
- Heat removal
- Reactor design
- Scale-up

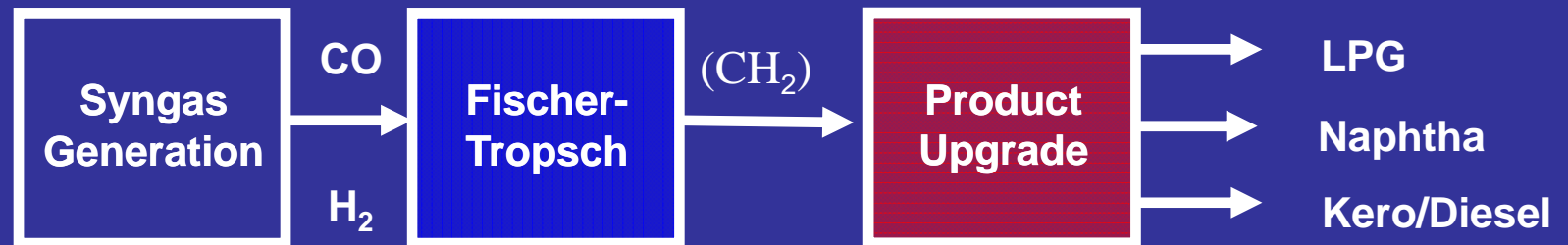

The Sasol Slurry *Bed Reactor* **Technical challenges**



The largest commercial-sized FT reactor - SASOL

Pictures Courtesy of Sasol

Technical challenges

Technology – *Product Upgrade*

- Catalyst
- Capacity

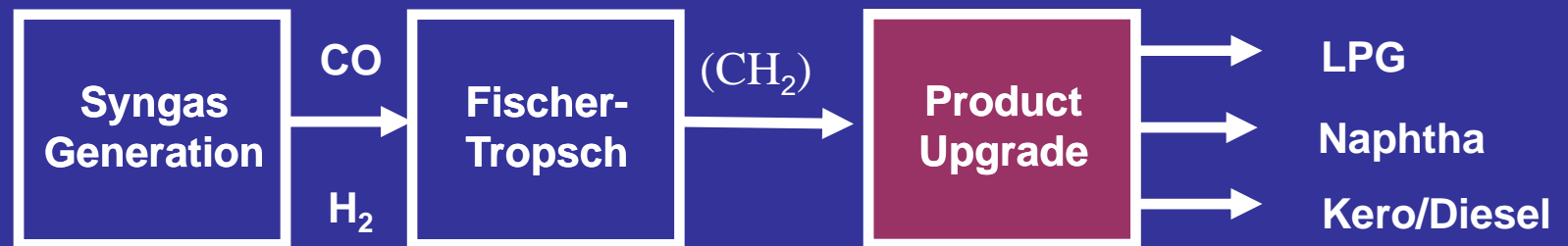

History

- 1902: Methane formed from H₂ and CO mixtures over Ni (Sabatier and Senderens);
- 1923: Fischer and Tropsch reported their work using Co, Fe, and Ru catalysts; at high pressure liquid hydrocarbon products formed over these catalysts;
- 1936: First four production plants commissioned in Germany (total capacity of 200,000 tons of hydrocarbons per year);
- 1944: Capacity of nine plants in Germany was increased to about 700,000 tons per year; Co based catalyst used in all production plants (development work on Fe catalysts continued but Fe not used to replace Co in production plant until after the 2nd WW);

History

- 1950: 5,000 bpd Hydrocol plant in Brownsville, Texas operated briefly (based on fixed fluid bed reactor, Fe-K catalyst, syngas from methane)
- 1950-53: Koelbel in Germany tested slurry phase F-T in pilot unit, 1.5 m diameter (Rheinpreussen plant)
- 1950s Bureau of Mines plant in Louisiana, Missouri, operated briefly (Fe catalyst)
- Mid 1950's German plants were shut down after operating briefly on petroleum residue. Interest in F-T synthesis declined worldwide with the discovery of abundant oil deposits in the Middle East.
- Except in South Africa where the first Sasol plant (Sasol I) was commissioned in 1955 (Based on Fe catalyst, Arge fixed bed and circulating fluid bed reactors); These were followed by Sasol II (1980) and Sasol III (1983), based on Synthol circulating fluid bed technology

NOVOCHERKASSK SYNTHETIC PRODUCTS PLANT 1954-1992

● Design FT Plant

- Planned capacity 50,000 tpy
- Primary commercial products
 - *n*-paraffins (C_5 - C_{24} reference cetane)
 - solvents (C_5 - C_6 and C_6 - C_7 paraffin fractions)
 - Oxidation feedstocks (paraffin fractions 179-270, 260-290°C)
 - solid paraffins (ceresin)

● Disadvantages

- Low process productivity
 - 4 t catalyst reactor load produces 2.5 t/day of C_{2+}
- Uneconomical production
- Co catalyst is no more than 9-12 months.

Novocherkassk

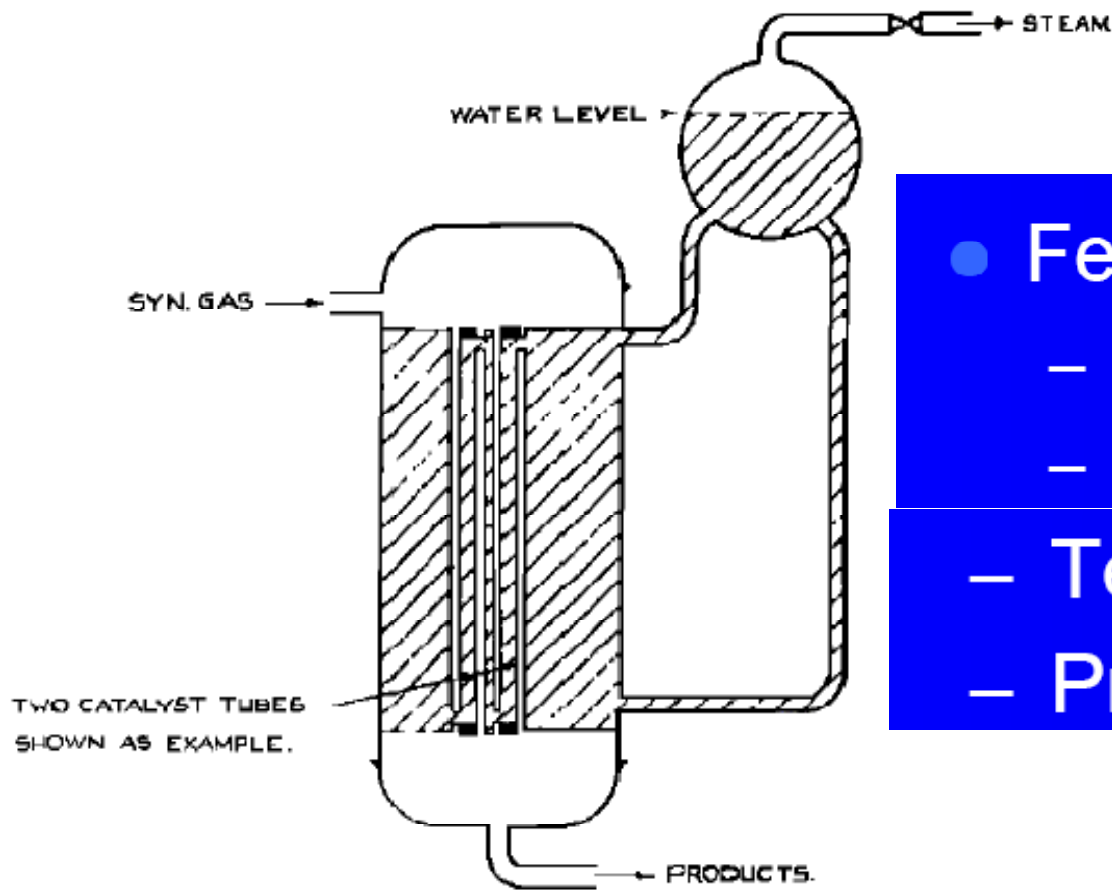

(B) REACTION VESSEL FOR MEDIUM PRESSURE SYNTHESIS.

- Feed
 - 1954 to 1978 anthracite
 - 1978 to 1992 natural gas
- Temp. 170 to 200° C
- Pressure 8-10 atm

Novocherkassk

- 1954- 1967 German Formulation
 - 100 Co, 8 MgO, 5 ThO₂, 200 kieselgur
- 1967 – 1977 Thoria Free Catalyst
 - 200 Co, 10 MgO, 260-280 kieselgur
- 1977 – 1981 Ceresin yield improvement
 - 100 Co, 10 ZrO₂, 200 kieselgur
- 1981-1992 Ceresin yield improvement
 - 100 Co, 10 MgO, 10 ZrO₂, 200 amorphous synthetic aluminosilicate

History

- 1970's and 1980's renewed interest in F-T synthesis due to increasing oil prices and fear of oil shortage
- 1990's further revival of F-T or GTL due to discoveries of huge "stranded" natural gas reserves, and requirements for cleaner fuels
- 1992: Mossgas large plant using Sasol technology and syngas from natural gas
- 1992-1993: Startup of Shell middle distillate 13 000 bbl/d plant in Malaysia (fixed bed reactor, Co catalyst and syngas from natural gas)
- 1993 Sasol slurry phase 2500 bbl/d F-T reactor (Fe catalyst)

FT Reactor Capacities

Historical overview

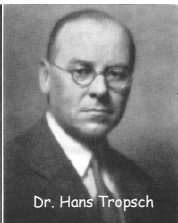
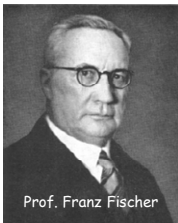
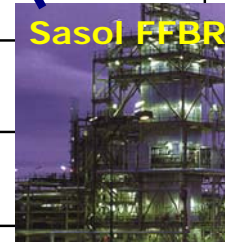
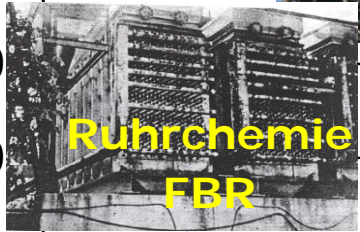
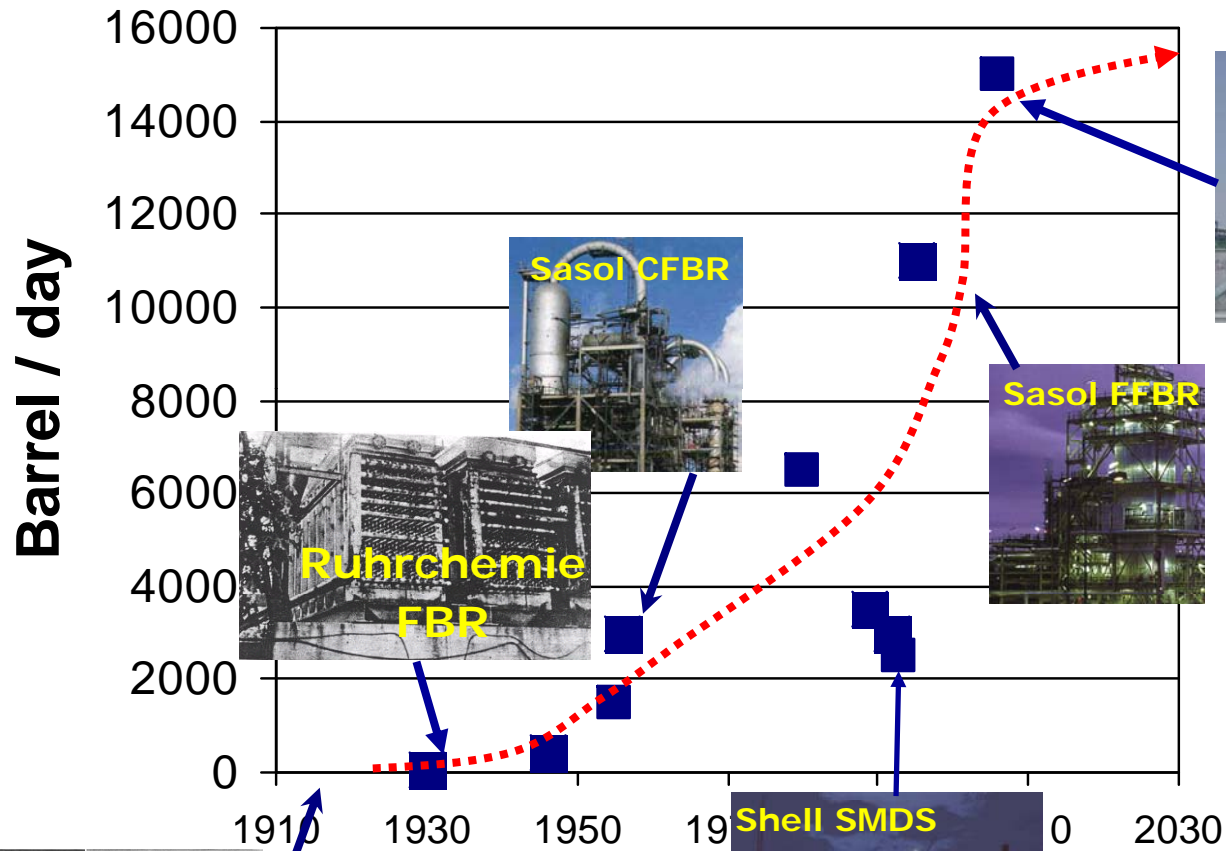



Sasol Plant, South Africa

Mechanism

- Exact mechanism very complex, not well defined, and still the subject of much debate
- F-T mechanism may be divided into at least 3 major steps:
 - 1. Initiation or C_1 compound formation by:
 - CO adsorption on catalyst metal surface
 - C – O bond breakage
 - Hydrogenation of $*C$ to $*CH_2$
 - 2. Hydrocarbon chain growth by;
 - Successive insertion of the C_1 building blocks
 - 3. Chain termination by:
 - Desorption of unsaturated surface species
 - Hydrogenation and desorption of saturated species

Products

- Product composition strongly influenced by
 - Catalyst composition
 - Product from cobalt catalyst higher in paraffins
 - Product from iron catalyst higher in olefins and oxygenates
 - Operating conditions
 - Temperature
 - Pressure
 - H₂/CO ratio
- However, essentially no aromatics except for high temperature processes, no nitrogen or sulfur compounds

F-T Products Blend: Carbon Number Distribution
by GC Analysis - Alpha = 0.89

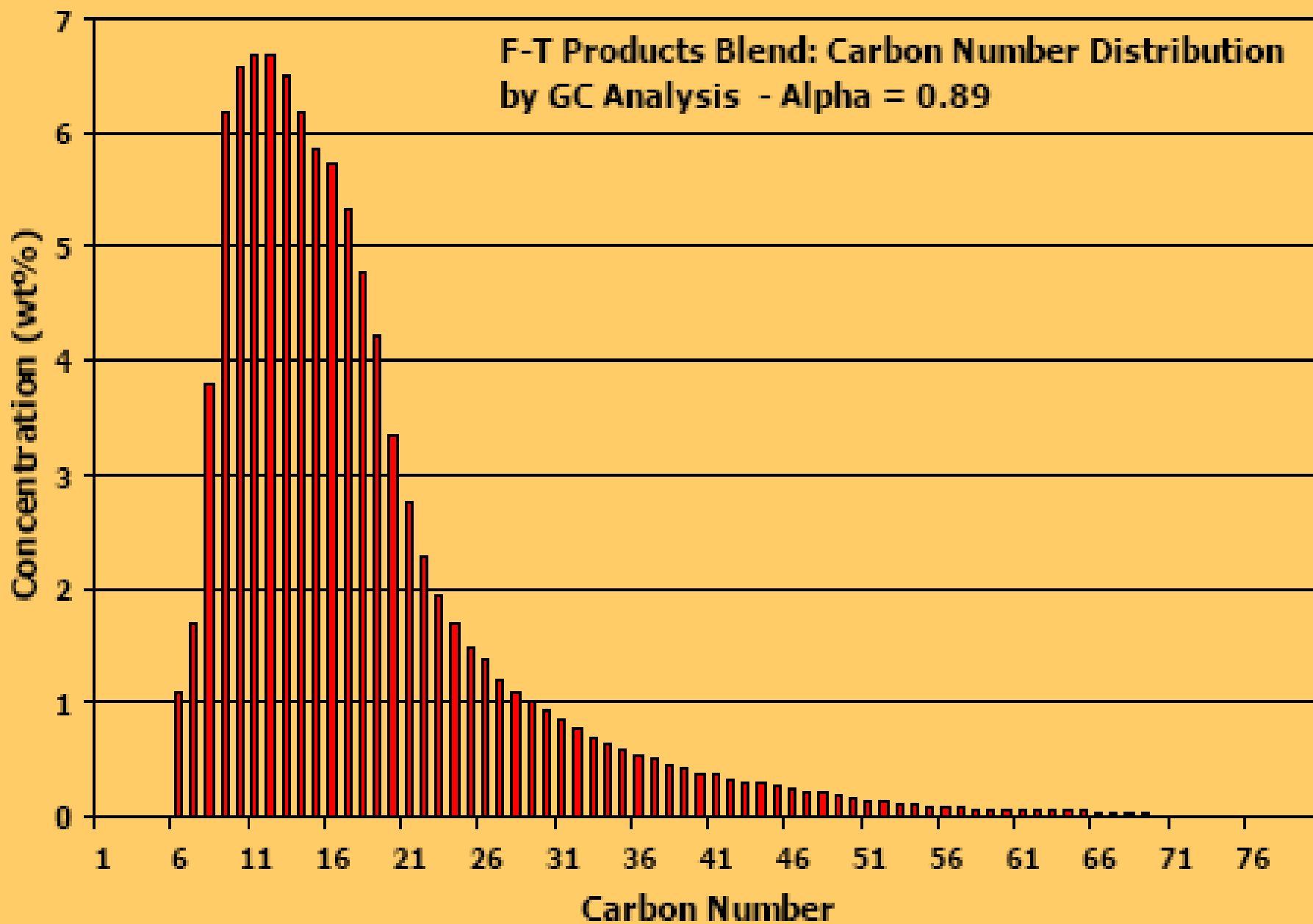

- F-T chemistry can be viewed as a polymerization reaction
- Applying polymerization kinetics, a simple one-parameter equation can describe the entire product distribution, referred to as the Anderson-Shultz-Flory (A-S-F) distribution:

$$W_n = (1-\alpha)^2 n \alpha^{n-1}$$

where:

n = carbon number

W_n = Weight fraction of product with carbon number n

α = Chain growth probability

- The higher the value of α the longer the average chain length

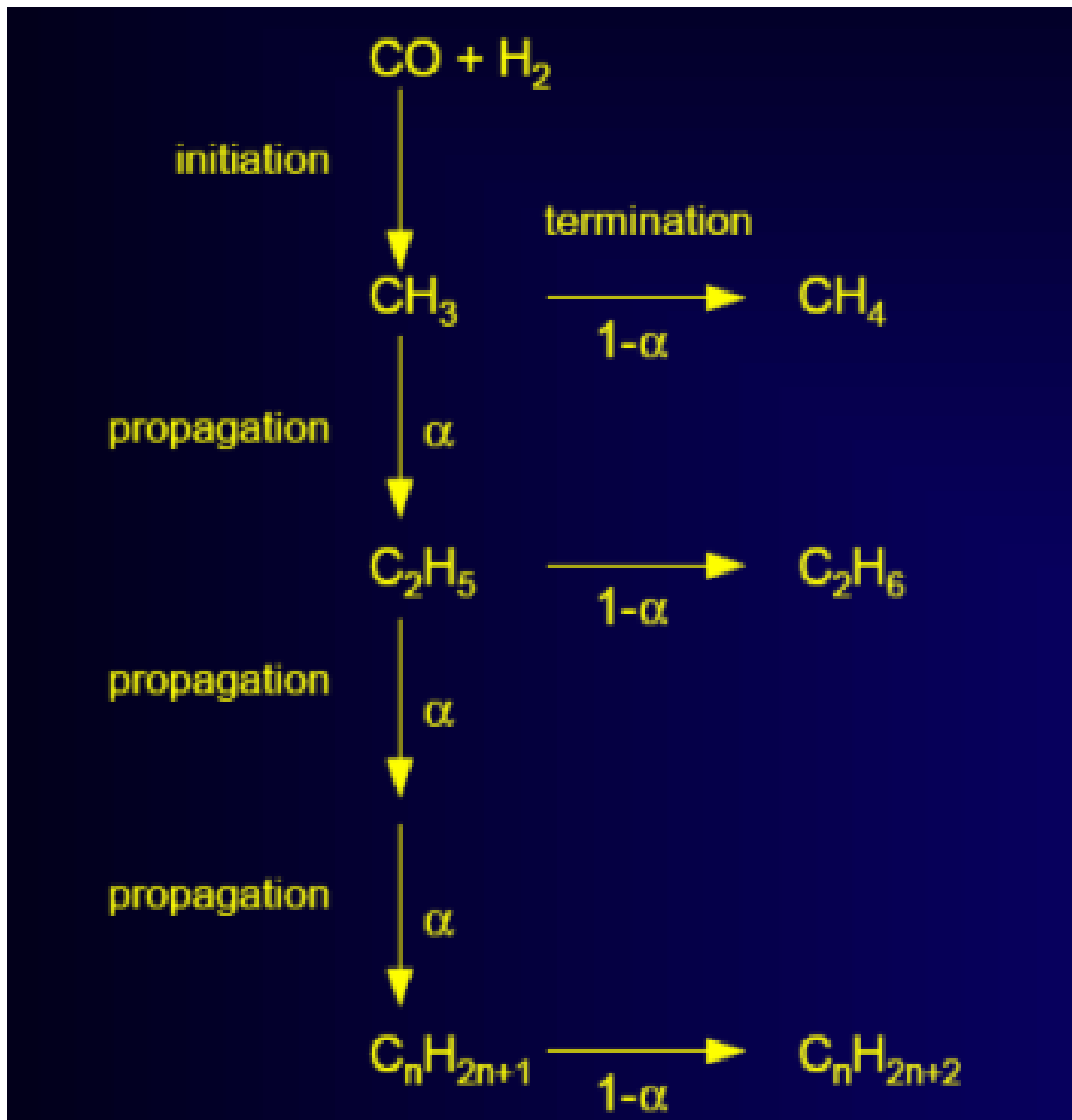

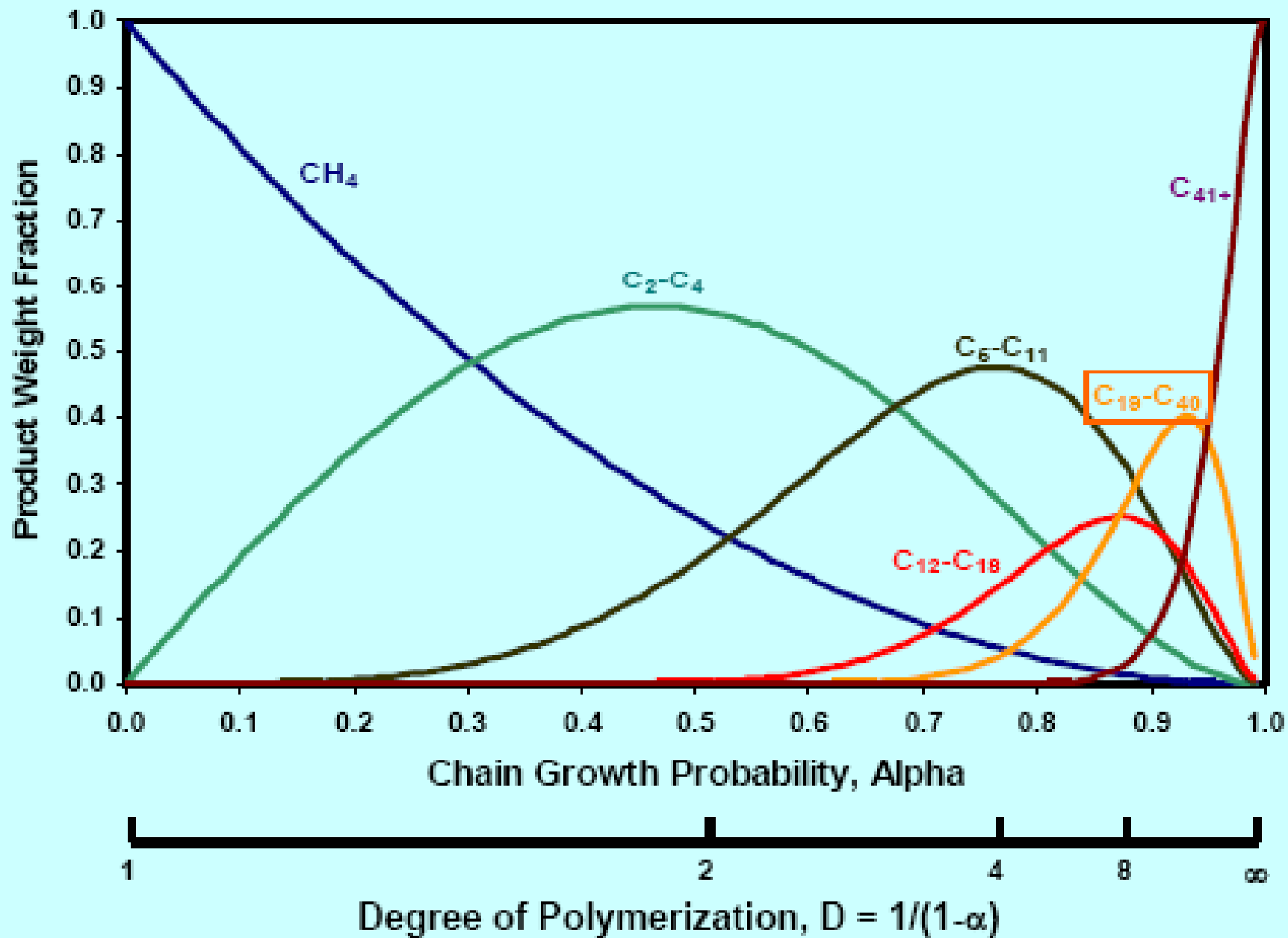

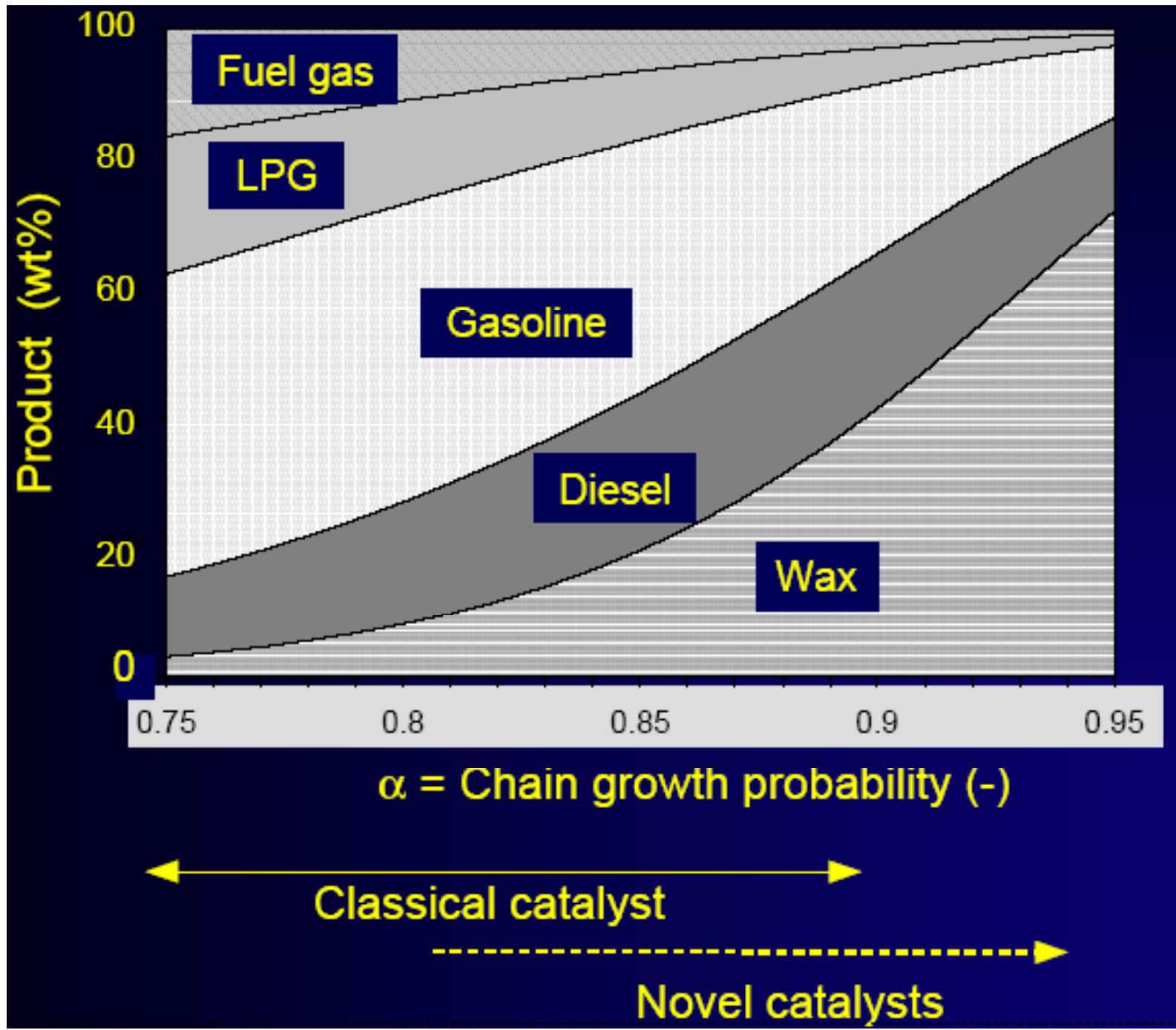

Kinetics

- F-T chemistry often modeled by a simple power law equation:

$$-r_{\text{CO}} = A e^{-E/RT} p_{\text{H}_2}^m p_{\text{CO}}^n$$

where:

r_{CO} = rate of conversion of CO

p_{H_2} , p_{CO} = partial pressure of H₂ and CO,
respectively

- In general m is positive (~ 1.0) and n is negative ($-0.1 - -0.35$)
- Energy of activation generally found in the range of 20 –25 kcal/gmol

Catalysts

SOURCE OF CARBON	F-T CATALYST	QUALIFICATIONS
Any	Ni	methanation
Carbon-rich [coal]	Fe	WGS activity with CO ₂ production
Hydrogen-rich [natural gas]	Co	Very active, linear hydrocarbons
	Ru	Very active, VERY EXPENSIVE!

Catalysts

- F-T Active Metal (Co, Fe, Ru)
- Reduction Promoters (Pt, Ru, Pd, Re, Cu)
- Activity/Selectivity Promoters (K, Zr, RE, etc.)
- Refractory oxide (Al_2O_3 , SiO_2 , TiO_2) used as supports or structural promoters

Fe

- Catalyst that has received most studies
- Used commercially in S. African F-T plant
- Generally preferred for coal-based syngas (low H_2/CO ratio)
- Can be prepared in several ways:
 - Fused iron oxide (used in Sasol's Synthol reactors); promoters added in the fusion step; much cheaper to prepare
 - Sintered iron oxide
 - Precipitated iron oxide which permits coprecipitation of additives and modifiers; however, more expensive to produce and has less structural strength
- Inherently unstable and gradually lose activity; cannot be regenerated; must be replaced periodically
- Structurally unstable for slurry reactor applications
- Typically promoted with copper to improve reducibility of Fe and an alkali (preferably K)

Co

- Generally preferred for natural gas-based syngas which is provided at close to or higher than F-T stoichiometric H_2/CO ratio
- Its low WGS activity, an advantage for such syngas
- Earlier Co catalysts prepared by coprecipitation methods
- New generation of Co catalysts prepared mostly by impregnation of oxide supports, using aqueous or organic solutions of Co nitrates and other additives
- Nitrates easily decomposed by calcination
- Co oxide usually pre-reduced in a H_2 containing gas to convert it to a metal active state
- Co catalyst currently used commercially in Shell F-T plant in Malaysia, and the catalyst of choice in most if not all future F-T plants based on natural gas feedstock

Cobalt Particle Size Effects in the Fischer–Tropsch Reaction Studied with Carbon Nanofiber Supported Catalysts

G. Leendert Bezemer,[†] Johannes H. Bitter,[†] Herman P. C. E. Kuipers,[‡] Heiko Oosterbeek,[‡] Johannes E. Holewijn,[‡] Xiaoding Xu,[§] Freek Kapteijn,[§] A. Jos van Dillen,[†] and Krijn P. de Jong^{*†}

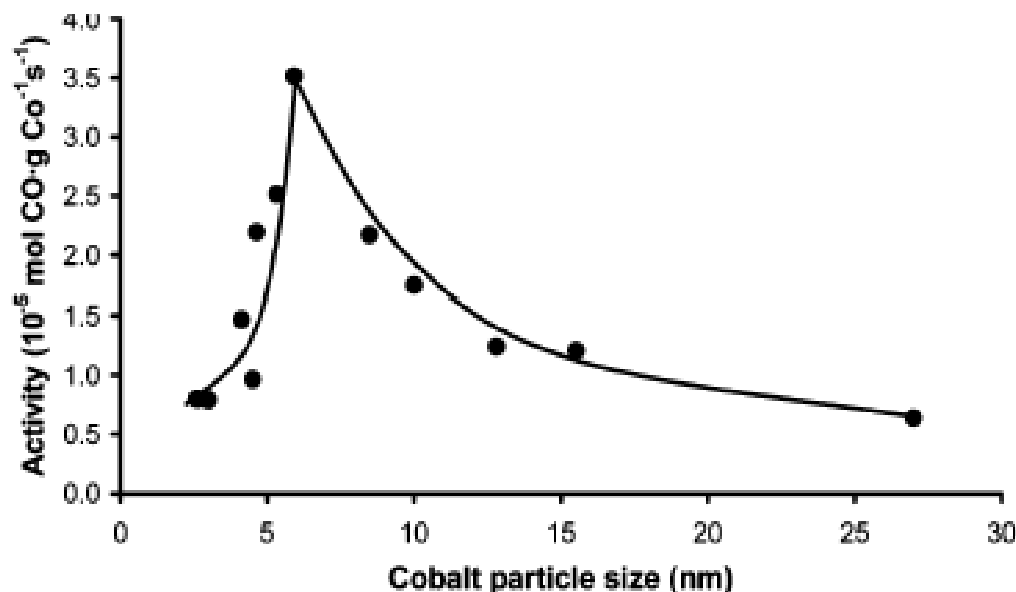

Figure 7. The influence of cobalt particle size on activity normalized to the cobalt loading (220 °C, $\text{H}_2/\text{CO} = 2$, 1 bar).

Co catalysts

- Support (Al_2O_3 , SiO_2 , TiO_2)
 - High surface area adsorbent
 - Adequate particle size distribution
 - Chemically and physically stable in environment of:
 - Catalyst preparation
 - Catalyst activation/regeneration
 - F-T reaction
- Active Metal
 - Cobalt chemically activates sorbed CO and enables its hydrogenation
 - Uniformly distributed on support
 - Active only in metallic form
 - Stable in synthesis environment

Co catalysts

- Oxide promoters (from groups IA, IIA, IIIA, IVA or VA of the periodic table)
 - Stabilize the dispersion of cobalt on catalyst surface
 - Promote hydrocarbon chain growth
 - Limit cobalt-support compound formation

- Noble metal promoters (Pt group metals)
 - Facilitate reduction of cobalt oxide to metal during:
 - Catalyst activation
 - Catalyst regeneration

Summary: FT Catalyst

+ Active Phase: Cobalt, Iron

Co based catalyst

- ✦ Expensive
- ✦ High selectivity to long chain paraffins
- ✦ Low selectivity to olefins and oxygenates
- ✦ resistant to deactivation
- ✦ limited WGS activity

Fe based catalyst

- ✦ Economic
- ✦ Low selectivity to long chain paraffins
- ✦ High selectivity to olefins and oxygenates
- ✦ WGS catalyst
- ✦ Fast deactivation (coke)

+ Promoter

- ✦ Structural: increase metal dispersion (Re, Zr, Hf, Ce)
- ✦ Reduction: increase extent of reduction (Ru, Pd, Pt, Cu)
- ✦ Activity: prevent coke deposition (Noble Metals)
- ✦ Selectivity: alter the product distribution (Na, K, Cs)

+ Carrier: SiO_2 , Al_2O_3 , TiO_2 , mix

- ✦ Structural promoter itself
- ✦ Influence selectivity due to secondary reaction (i.e. acid sites)

Catalysts

Company	Typical Catalyst Constituents			
	Primary	Reduction Promoter	Activity/Selectivity Promoter	Support
Conoco	Co	Re, other	N/A	Alumina, other
Gulf (Shell)	Co	Ru	oxide promoters	alumina
Exxon	Co	Re/Ru	oxide promoters	titania or TiO ₂ /silica
IFP	Co			
Intevap	Co	-	oxide and carbide promoters	Silica
Rentech	Fe	N/A	N/A	-
Shell	Co	with or w/o a noble metal	ZrO ₂	Silica, silica-alumina
Statoil	Co	Re	oxide promoters	alumina
SASOL	(Fe) Co	Pt	-	alumina
Williams	Co	with or w/o a noble metal	with or w/o oxide promoters	doped alumina

Reactors

- F-T reaction is highly exothermic
- Heat removal is a major consideration when designing a F-T reactor
- Selectivity to methane increases with increasing temperature
- Close temperature control necessary in order to maintain desired selectivity
- Three major types of reactors are considered for F-T process:
 - Tubular fixed bed reactor
 - Fluidized bed reactor
 - Slurry reactor

Multi-tubular fixed-bed reactor

- First reactor type to be exploited commercially, e.g., Arge reactor
- TFB reactors used in Sasol I in South Africa and Shell plant in Malaysia
- Catalyst in pellet shape are placed in the tubes and the cooling medium flows around the outside of the tubes, similar to a shell and tube heat exchanger

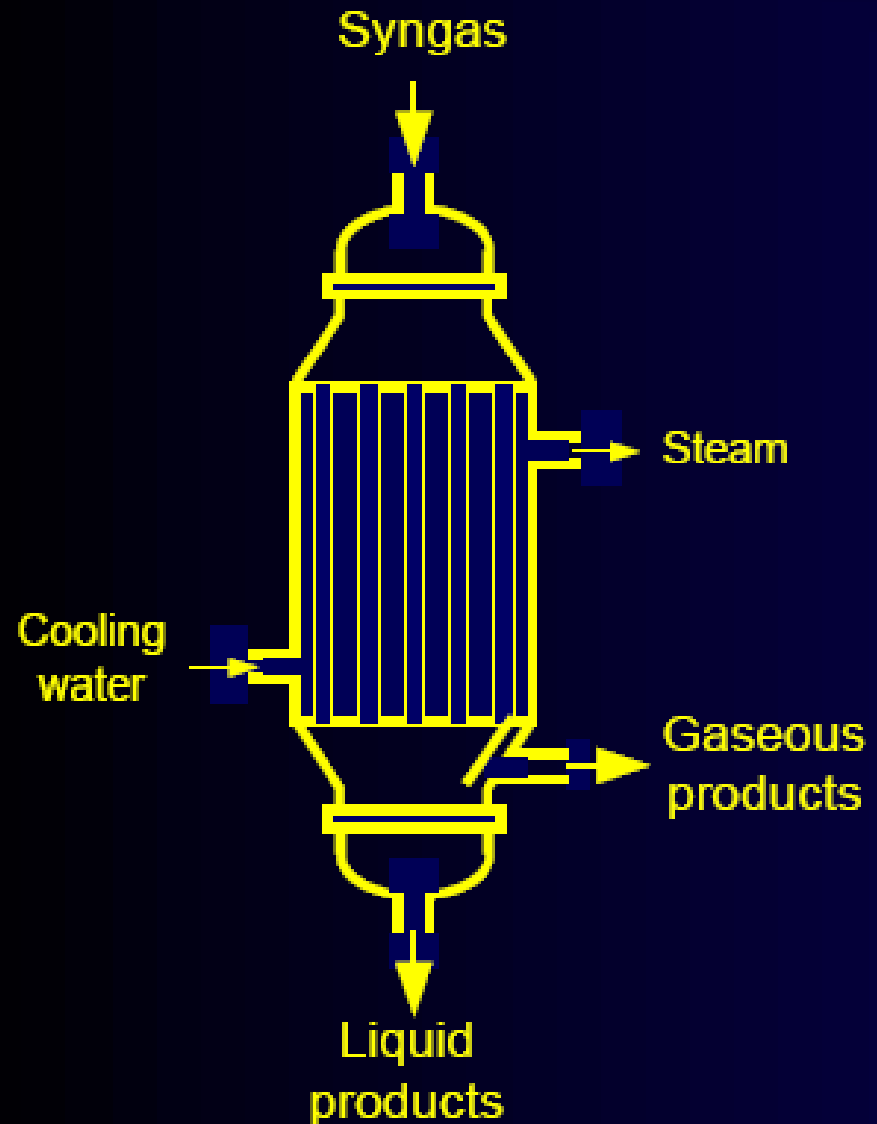

Fixed bed

- Relatively simple design, but expensive construction with its large number of tubes required for a commercial scale plant
- Easy to scale-up from a single tube pilot plant
- Catalyst replacement is a major undertaking
- Iron catalysts inherently unstable have to be replaced periodically
- More stable cobalt catalysts can be regenerated and reactivated in-situ; may not have to be replaced for several year
- May experience temperature gradients in the tubes which can lead to catalyst sintering and deactivation
- Can also experience high pressure drop in tubes

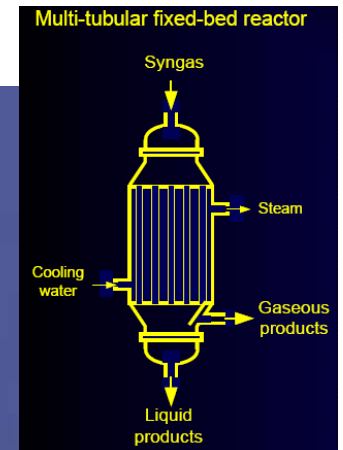

Catalyst $d > 1\text{mm}$; Effectiveness factor below unity

Reactors

- Two types of FB reactors:
 - Circulating fluidized bed (CFB) reactor such as the Sasol's Synthol reactor
 - Fixed fluidized bed reactor (Sasol Advanced Synthol, SAS reactor)
- CFB reactors used in Sasol I and II
- Better heat removal
- Better temperature control
- Less pressure drop problems
- Online catalyst removal and addition possible

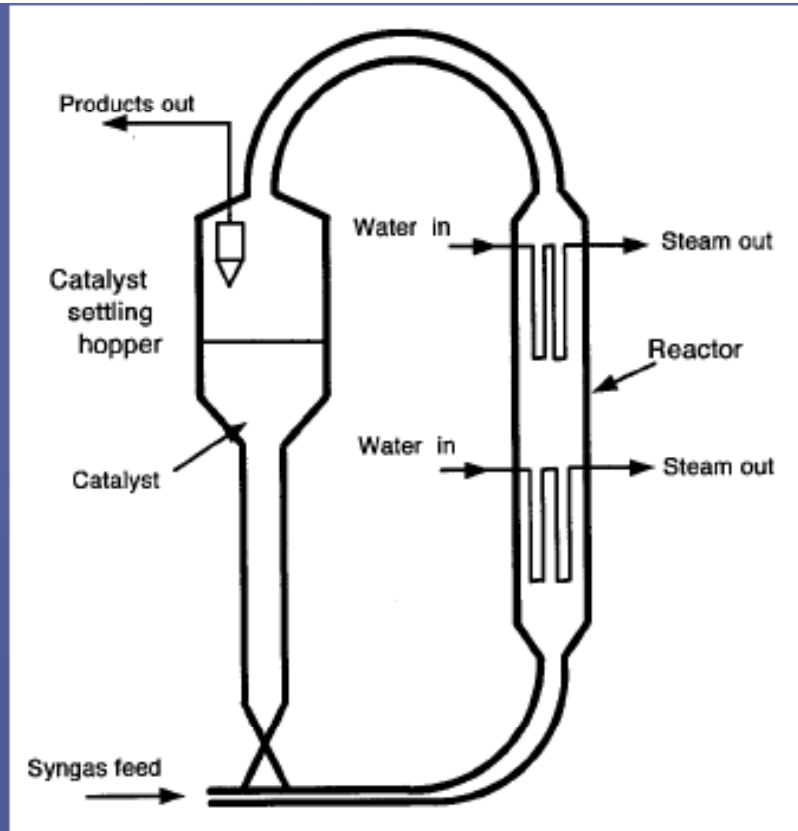

Sasol's (Synthol) Circulating Fluidized Bed Reactor

Fluidized beds

- Major disadvantage of fluidized beds for F-T applications: Product must be volatile at the reaction conditions
- Non-volatile hydrocarbons can accumulate on catalyst particles, making them sticky and adhering to each other; the bed loses its fluidization properties
- Thus, the F-T products of fluidized bed reactors must be of relatively low molecular weight
- More difficult to scale-up than TBF reactors, because the fluidization behavior function of the reactor diameter
- However, there is a wide experience with large fluidized bed reactors in refining, such as FCC units; thus fluidized bed reactors can be scaled-up with confidence

Slurry

The slurry-phase bubble column reactor (SBCR) considered the primary choice for the newer F-T processes using highly active cobalt catalysts

In a SBCR syngas is bubbled up through a slurry made up of hydrocarbon wax, liquid at the reaction conditions, and a catalyst suspended in it

The catalyst is a finely divided powder with an average particle size of 50-80 μm

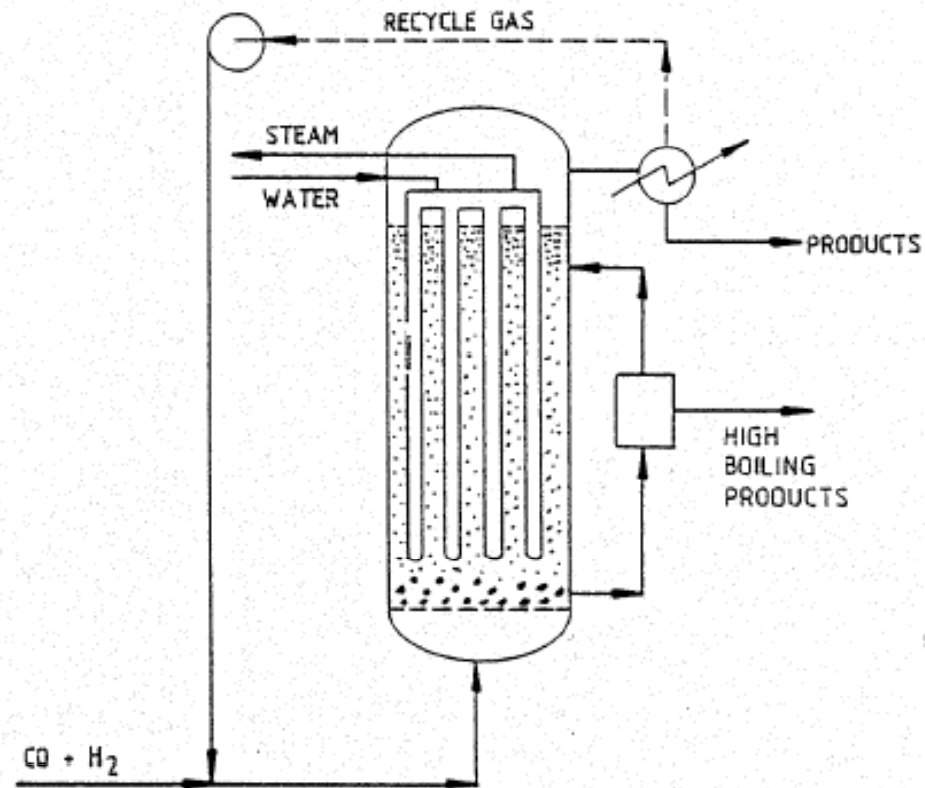

Slurry

- Advantages provided by the use of SBCR:
 - Good heat transfer
 - Excellent temperature control
 - Better selectivity control
 - Ideal for higher boiling products
 - Low pressure drop
 - Ease of adding and removing catalyst
 - Simple design and construction
 - Potentially high capacity (10000-20000 bbl/d)
- The gaseous products are removed from the top of the reactor, while the heavy non-volatile wax must be separated from the catalyst which remains in the reactor
- Various proprietary internal or external filtration systems have been devised

Operation

- Operating conditions influenced by reactor type as well as the nature of the catalyst
- Main controlling parameters:
 - Temperature: 220-350 °C for iron; 200-250 °C for cobalt; high temperature required for fluidized bed reactors
 - Pressure: atmospheric – 500 psi
 - Space velocity: 100-1000 h⁻¹
 - H₂/CO ratio depends on the source of syngas and type of catalyst
 - Optimum per pass conversion may be more of an economical decision than a technical one

Reactor comparison

	Multi-tubular fixed-bed reactor	Riser reactor	Slurry reactor
Conditions			
Inlet T (K)	496	593	533
Outlet T (K)	509	598	538
Pressure (bar)	25	23	15
H ₂ /CO feed ratio	1.7	2.54	0.68*
Conversion (%)	60 – 66	85	87
Products (wt%)			
CH ₄	2.0	10.0	6.8
C ₂ H ₄	0.1	4.0	1.6
C ₂ H ₆	1.8	4.0	2.8
C ₃ H ₆	2.7	12.0	7.5
C ₃ H ₈	1.7	1.7	1.8
C ₄ H ₈	2.8	9.4	6.2
C ₄ H ₁₀	1.7	1.9	1.8
C ₅ – C ₁₁ (gasoline)	18.0	40.0	18.6
C ₁₂ – C ₁₈ (diesel)	14.0	7.0	14.3
C ₁₉ ⁺ (waxes)	52.0	4.0	37.6
Oxygenates	3.2	6.0	1.0

Technologies

In use/Ready to go

Company	Reactor	Catalyst
Shell SMDS	FB	Co
SASOL SPD	SBCR	Co
Exxon AGC-21	SBCR	Co
Rentech	SBCR	Fe
Syntroleum	FB	Co

Plants

EXISTING PLANTS

Owner	Location	Products	Capacity,b/d	Feedstock	Start date
SASOL I	Sasolburg	Fuels/Specialty	2,500	Coal	1955
SASOL II	Secunda	Fuels/Specialty	85,000	Coal	1980
SASOL III	Secunda	Fuels/Specialty	85,000	Coal	1982
NZ Synfuels	New Plymouth	Fuels	12,000	Natural Gas	1985
Shell	Bintulu	Fuels/Specialty	12,500	Natural Gas	1993
MossGass	Mossel Bay	Fuels/Specialty	30,000	Natural Gas	1992

PLANNED COMMERCIAL PLANTS

Owner	Location	Products	Capacity,b/d	Feedstock	Start date
Exxon/Mobil	Qatar	Fuels	80,000	Natural Gas	2005
Sasol/Qatar	Qatar	Fuels	34,000	Natural Gas	2005
Chevron	Nigeria	Fuels/Specialty	34,000	Natural Gas	2005
Syntroleum	Australia	Specialty	11,500	Natural Gas	2005

Table 1 Fischer–Tropsch processes currently in industrial operation

Type	FT catalyst	FT reactor type	FT technology	Operator	Commercial operation
HTFT	fused Fe	circulating fluidised bed	Sasol Synthol	PetroSA	Mossel Bay, South Africa
HTFT	fused Fe	fixed fluidised bed	Sasol Advanced Synthol (SAS)	Sasol	Secunda, South Africa
LTFT	precipitated Fe	fixed bed	ARGE ^a	Sasol	Sasolburg, South Africa
LTFT	precipitated Fe	slurry bubble column	Sasol Slurry Bed Process (SSBP)	Sasol	Sasolburg, South Africa
LTFT	Co-SiO ₂	fixed bed	Shell Middle Distillate Synthesis (SMDS)	Shell	Bintulu, Malaysia
LTFT	Co-Al ₂ O ₃	slurry bubble column	Sasol Slurry Bed Process (SSBP)	Sasol	Ras Laffan, Qatar

^a ARGE = Arbeitsgemeinschaft Ruhrchemie-Lurgi.

Products from GTL-FT process

Typical FT product composition after upgrading is:

25% Virgin Naphtha, 25% Jet Fuel and 50% Diesel

and minor amounts of LPG and bottom hydrocracking. The heavier fraction can be used for the production of lubricating bases or chemicals.

**Refinery Barrel Yield
(Brent, vol)**

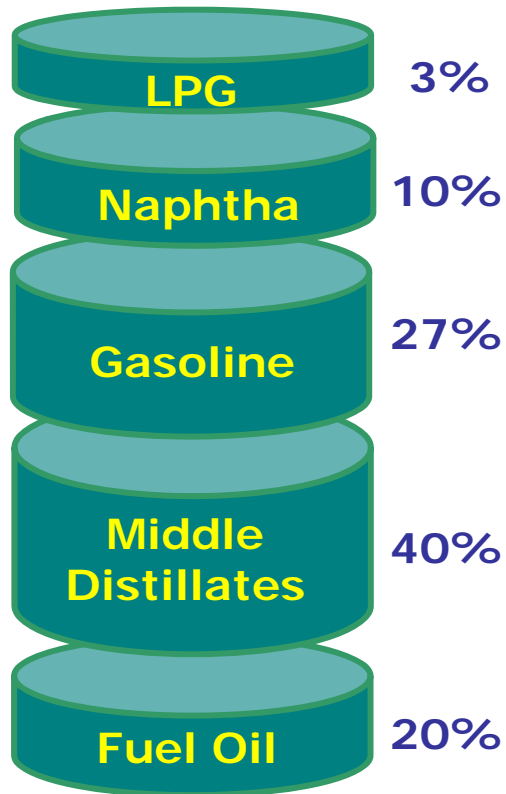

**GTL Barrel
(vol)**

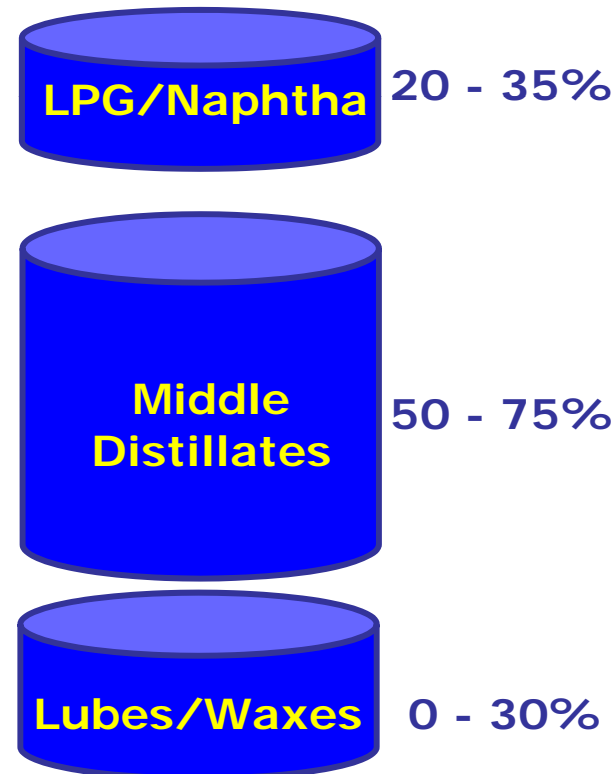

GtL Technology: Hydrocracking

Conventional vs. GtL Diesel

Quality	Conventional Diesel	SWCL1	Blu Diesel Agip	FT – Diesel #
Boiling range (°C)	180-360	180-275	180-360	150-360
Density @ 15°C (kg/m ³)	820 – 845	805	835	780
Sulfur (ppm vol)	50	6	4.5	< 1
Aromatics (% vol)	30	3	22	< 0.1
Cetane number (CN)	> 51	56	55	> 70
CFPP* (°C)	- 15	- 12	- 11	- 20
Cloud point (°C)	0	n.d.	-1	-15

* Cold Filter Plug Point;

Diesel from waxes produced on pilot runs

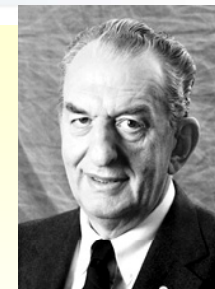

G.Olah : Beyond Oil and Gas: The Methanol Economy

- storing energy in the form of methanol
 - excellent fuel; easily stored, transported and used

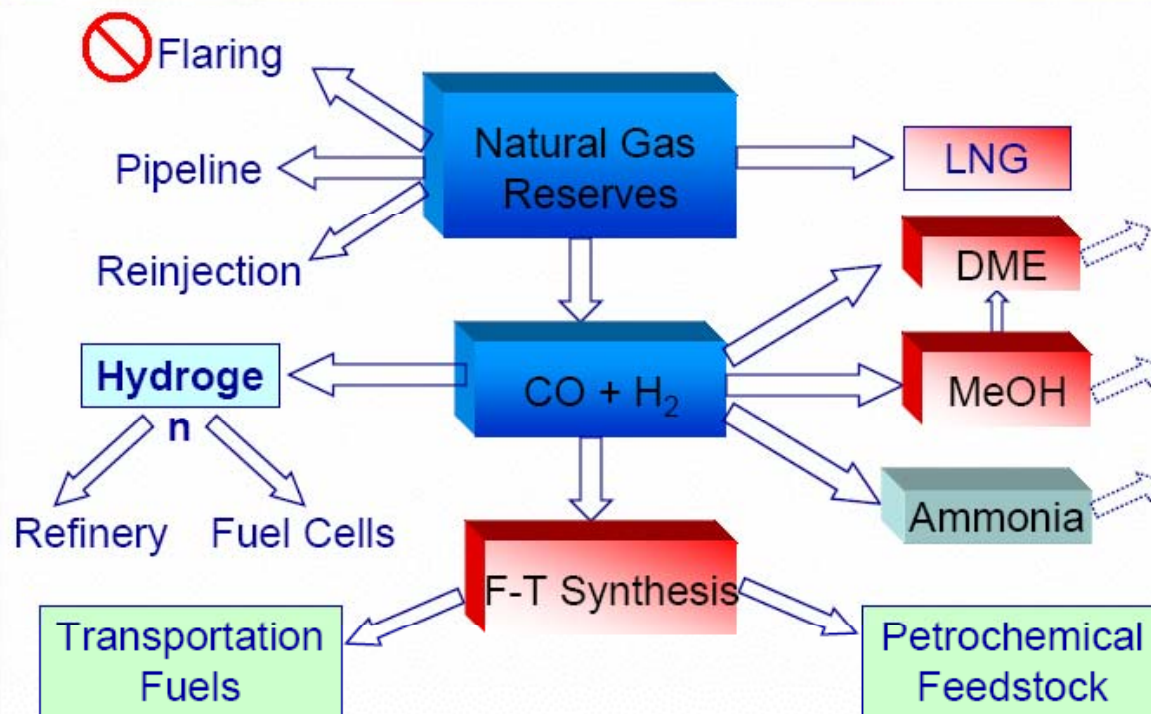

Methanol



T low

By-products: higher alcohols and hydrocarbons from CO

Phase: gas

Catalyst: selective CuZn/Al₂O₃

Methanol

Catalyst: sintering possible, thus $t < 200-270^{\circ}\text{C}$
deactivation by S, C \Rightarrow (purification)

Operation policy : pressure increase with deactivation (not T)

Gas composition: 74% H_2 , 15% CO , 8% CO_2 , 3% CH_4
 $p=50-100$ bar, conversion 15-30% in adiabatic reactor

Recycle of gases : recycle/make-up = 3-7 (range to avoid build up of CH_4 and Ar)

Products : distillation

Improvements: 1) remove heat to keep reaction T as low as possible

2) removal of methanol to shift equilibrium

3) more active catalyst

Mechanism of methanol formation

MECHANISM A

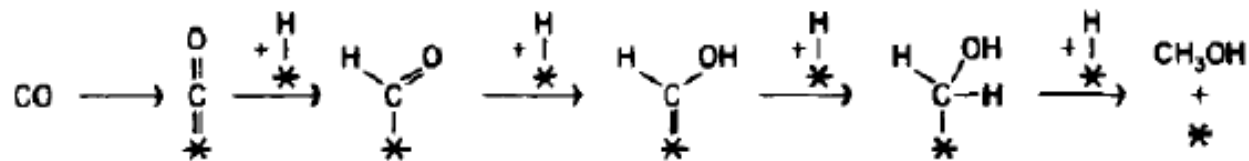

MECHANISM B

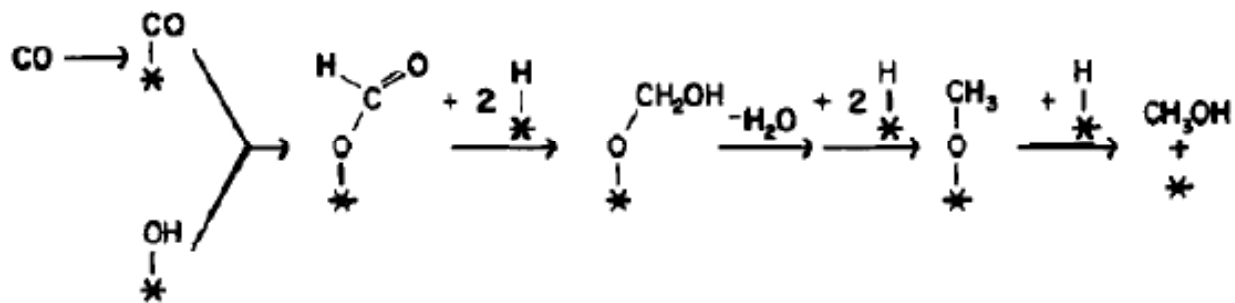

Methanol synthesis mechanism

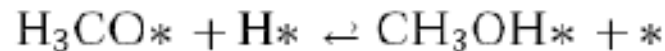
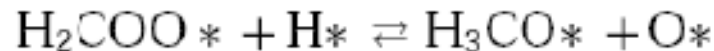
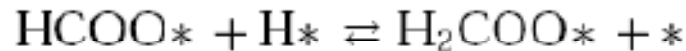
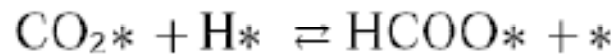
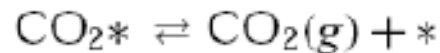
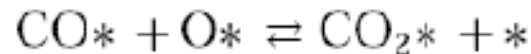
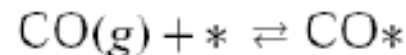
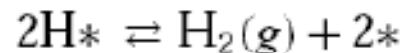
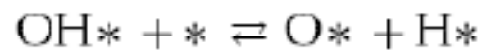
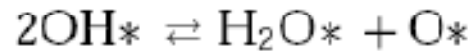
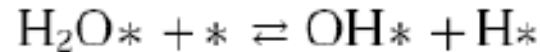
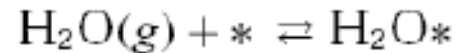

Rate determining step

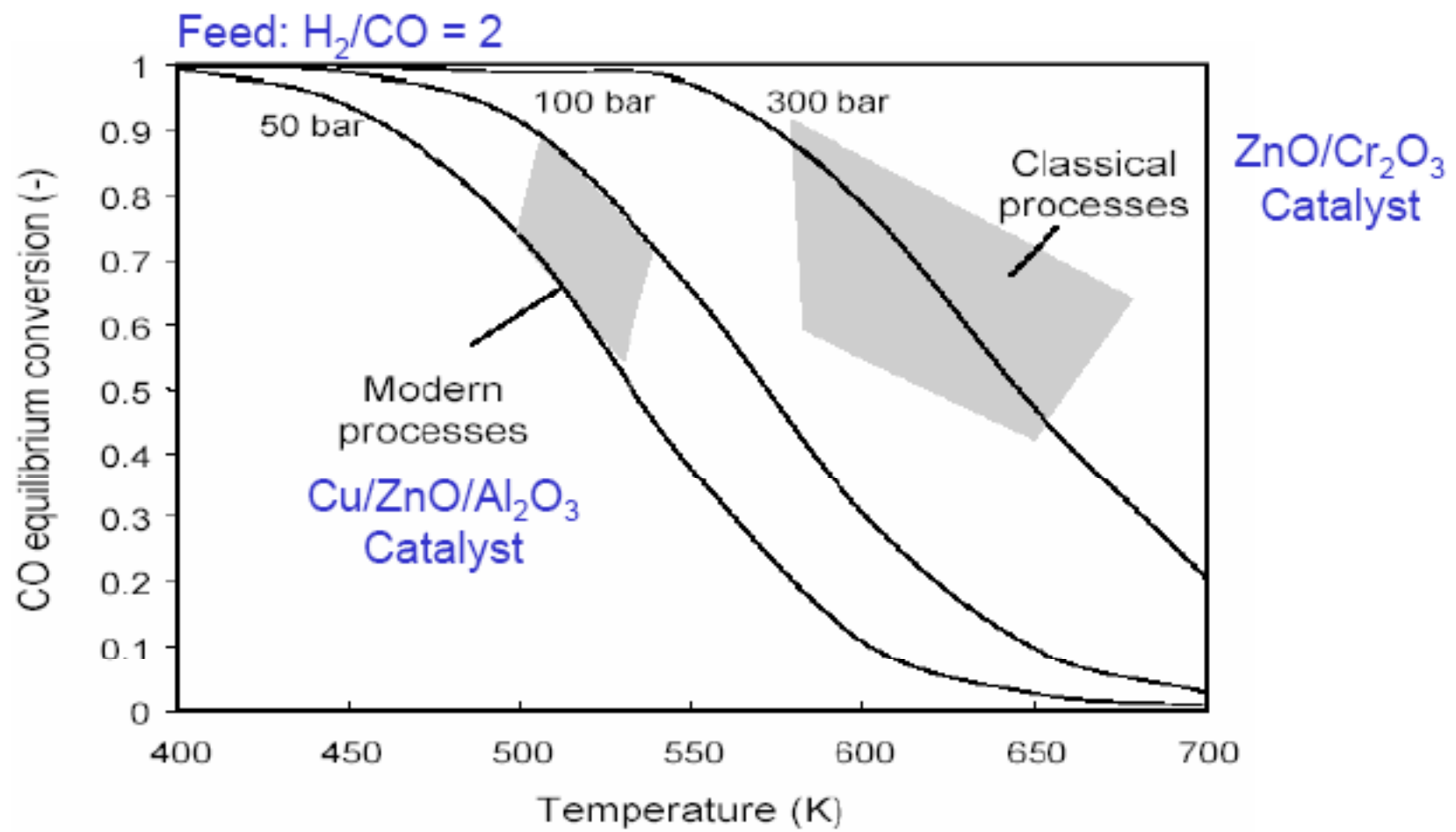

Methanol

Table 6.10 Equilibrium CO and CO₂ conversions, and exit CH₃OH concentration versus pressure and temperature^a for methanol synthesis (Wade *et al.*, 1981)

Temperature (°C)	CO conversion (%)			CO ₂ conversion (%)			Exit CH ₃ OH (vol %)		
	50 bar ^b	100 bar	300 bar	50 bar	100 bar	300 bar	50 bar	100 bar	300 bar
200	95.6	99.0	99.9	44.1	82.5	99.0	27.8	37.6	42.3
250	72.1	90.9	98.9	18.0	46.2	91.0	16.2	26.5	39.7
300	25.7	60.6	92.8	14.3	24.6	71.1	5.6	14.2	32.2
350	-2.3	16.9	73.0	19.8	23.6	52.1	1.3	4.8	21.7
400	-12.8	-7.2	38.1	27.9	30.1	44.2	0.3	1.4	11.4

^a Typical reformed natural gas composition 15% CO, 8% CO₂, 74% H₂, 3% CH₄; H₂/(2CO + 3CO₂) = 1.30; simplified single-pass operation, no recycle.

^b 1 bar = 1.013 atm.

Methanol synthesis

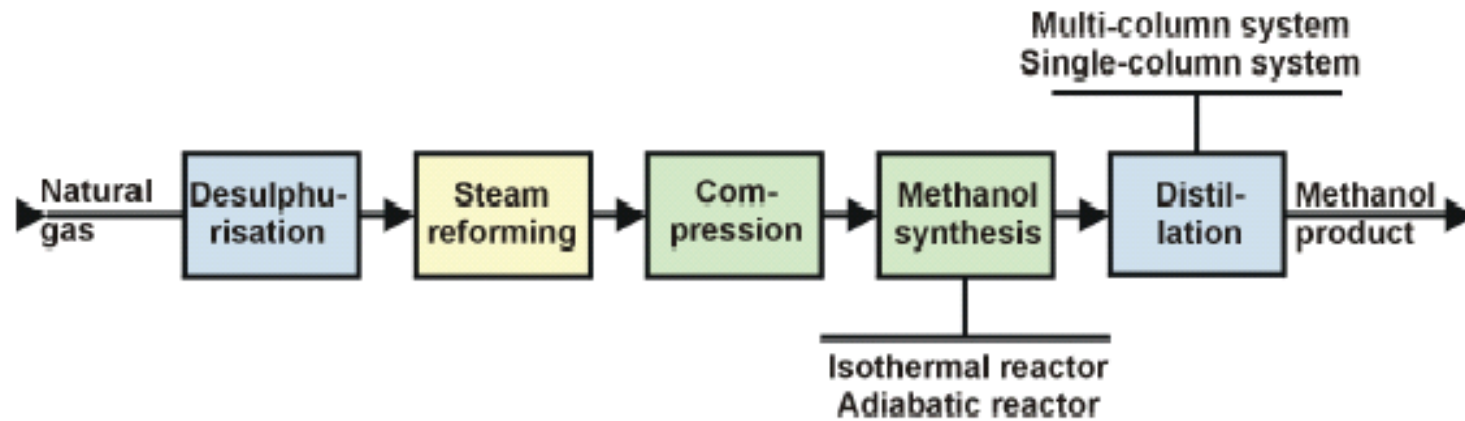

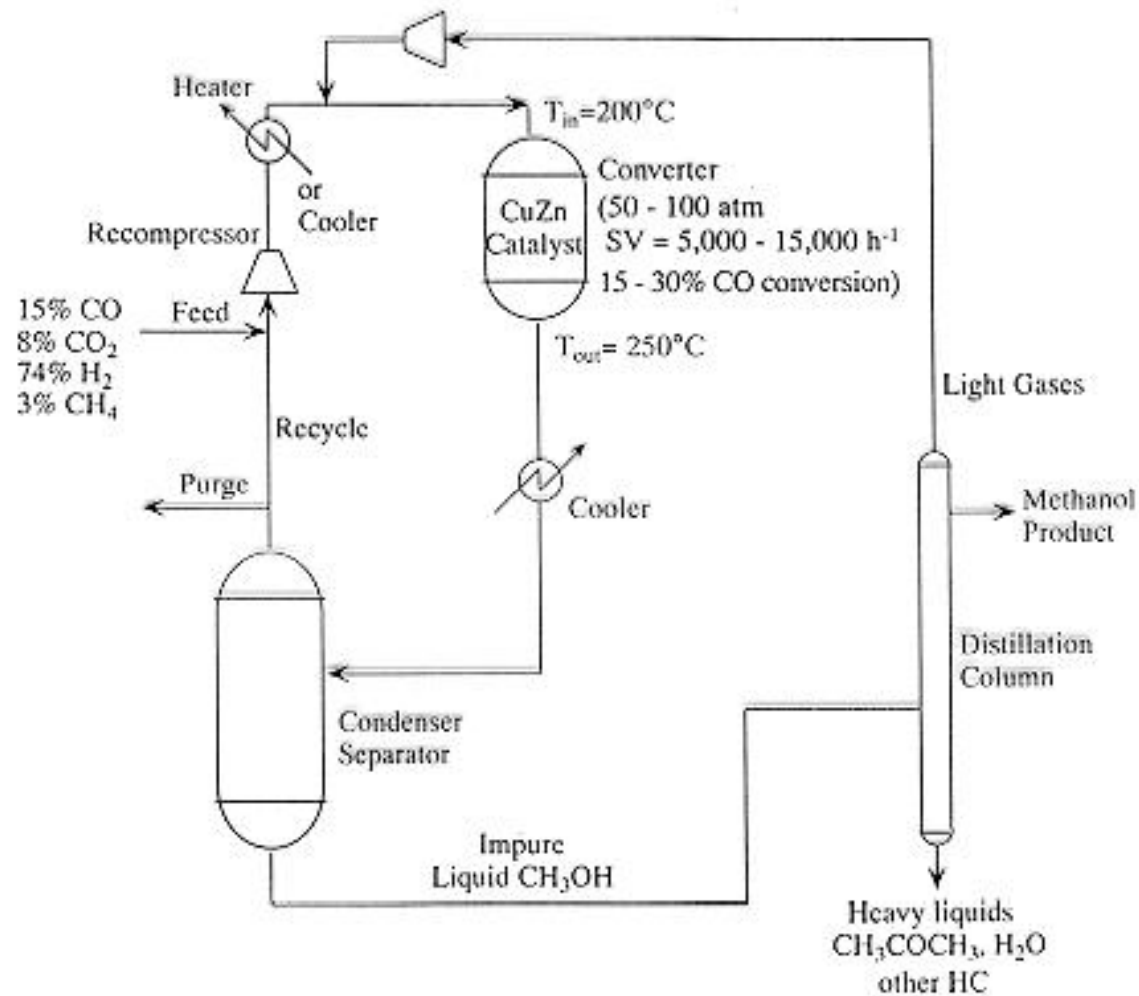
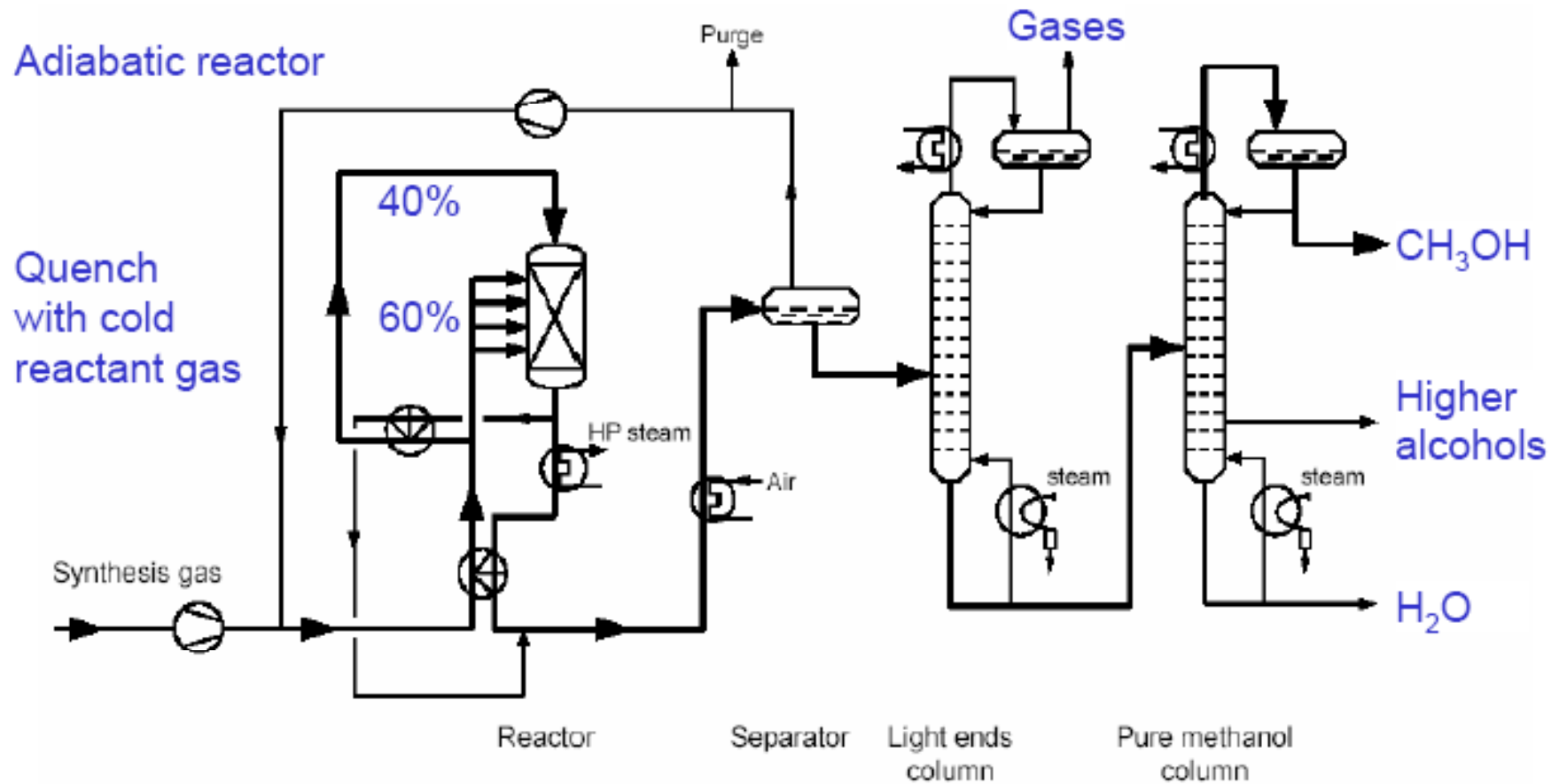

Figure 6.15 Flow sheet of typical low pressure methanol plant based on the steam reforming of natural gas.

ICI-low pressure methanol process



Heat exchanger

conversion

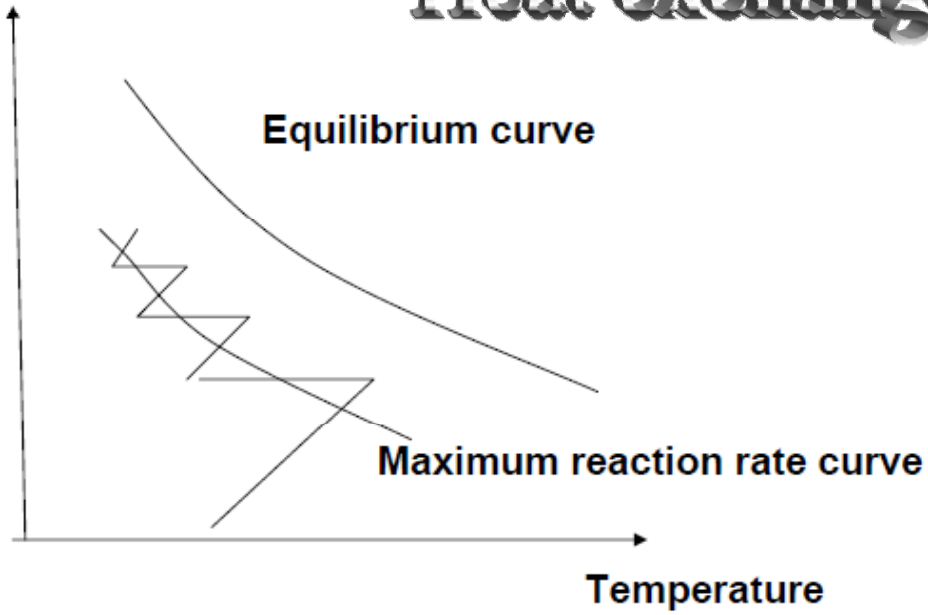

Quenching

Conversion
CO

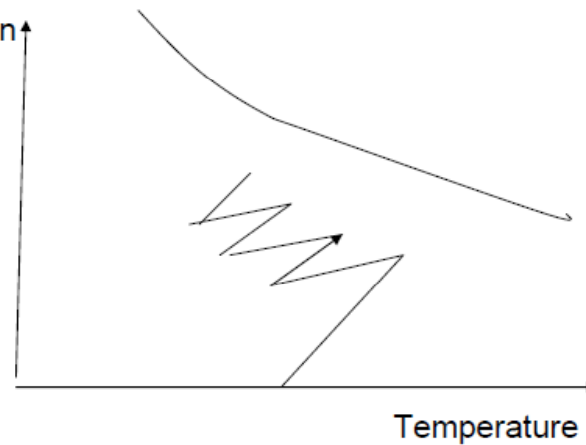

Catalysts

	Physical Properties (Typical)	Chemical Composition (Typical)	
	KATALCO 51-8		
Form	Cylindrical pellet	CuO:	64 wt%
Diameter	5.4 mm	Al ₂ O ₃ :	10 wt%
Length	5.2 mm	ZnO:	24 wt%
Bulk Density	1250 kg/m ³	MgO:	2 wt%
Crush Strength (axial)	80 kgr		

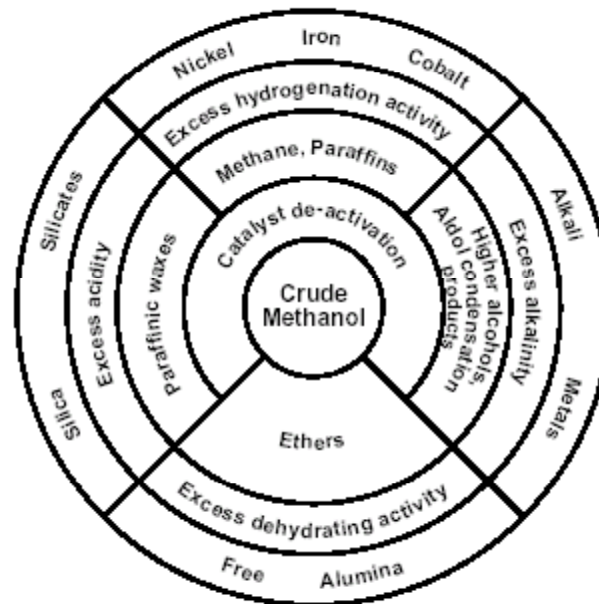

Catalyst Activity

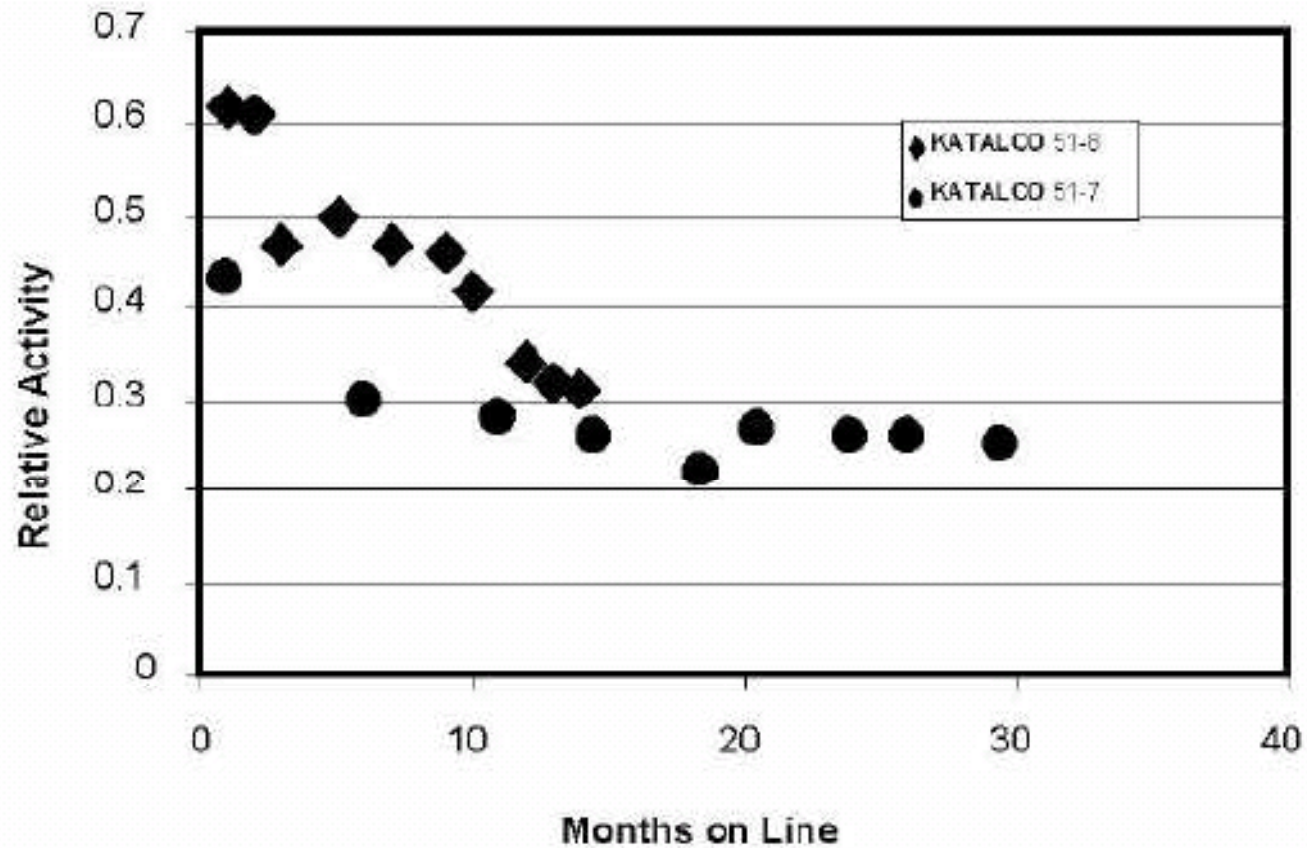

Operation policy: increase pressure, not T

Crude methanol analysis from a modern converter

Impurity (ppm w/w)	Start of run	Middle of run	End of run
Higher alcohols			
Ethanol	110	200	265
N-Propanol	35	60	80
Iso-Propanol	20	30	45
N-Butanol	10	15	20
Iso-Butanol	30	60	80
Sec-Butanol	10	20	35
Hydrocarbons			
N-Petane	<2	<2	<2
N-Hexane	<2	<2	<2
N-Heptane	<2	<2	<2
N-Octane	<2	<5	5
N-Nonane	<5	<5	5
N-Decane	<5	<5	5

Types of reactors used for efficient cooling

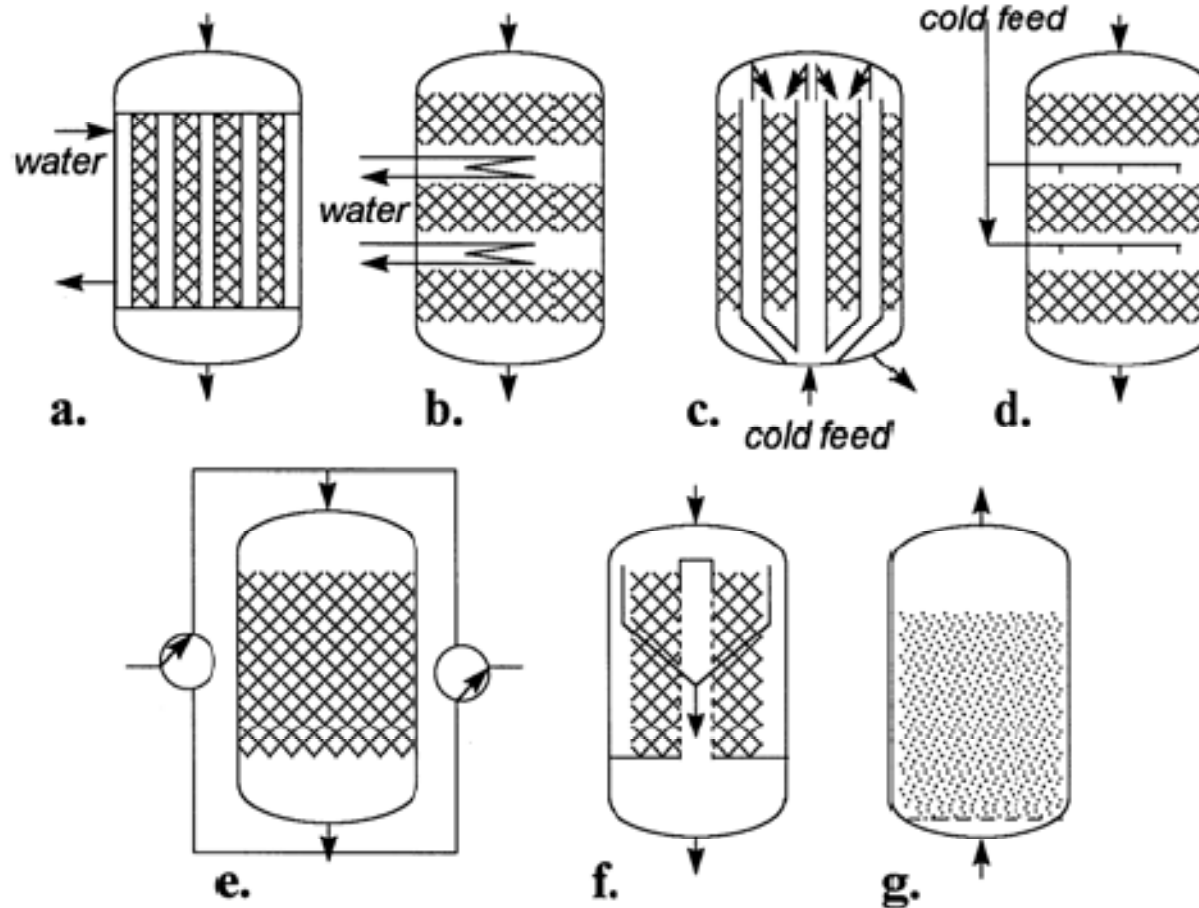

- (a) Cooling with water bath; (b) cooling with water coils; (c) cooling with cold feed; (d) feed gas quench; (e) feed-effluent heat exchange by periodic flow reversal; (f) lateral flow; (g) fluidised bed.

Reactor: isothermal

Uhde's isothermal reactor is a tubular reactor with a copper catalyst contained in vertical tubes and boiling water on the shell side. The methanol reaction heat is removed by partial evaporation of the boiler feed water, thus generating 1 metric ton of medium-pressure steam per 1.4 metric tons of methanol.

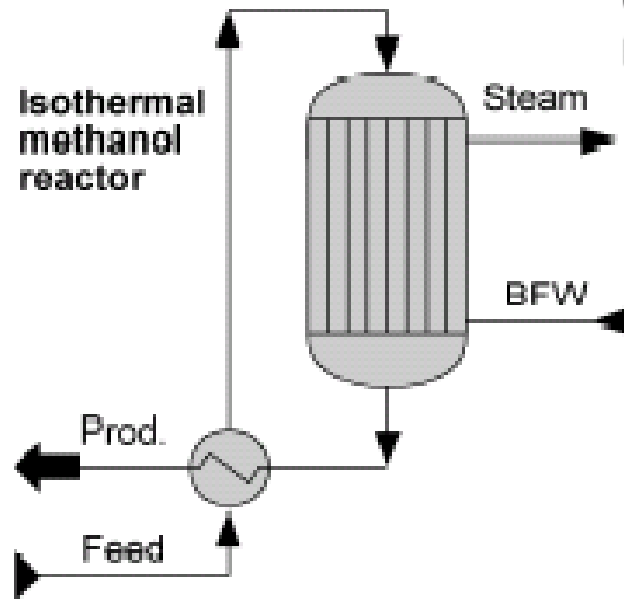

The advantages of this reactor type are: low by-product formation due to almost isothermal reaction conditions, high reaction heat recovery, and easy temperature control by regulating steam pressure.

To avoid the build-up of inert components in the loop, a purge is withdrawn from the recycle gas and used as fuel for the reformer.

Reactor: adiabatic

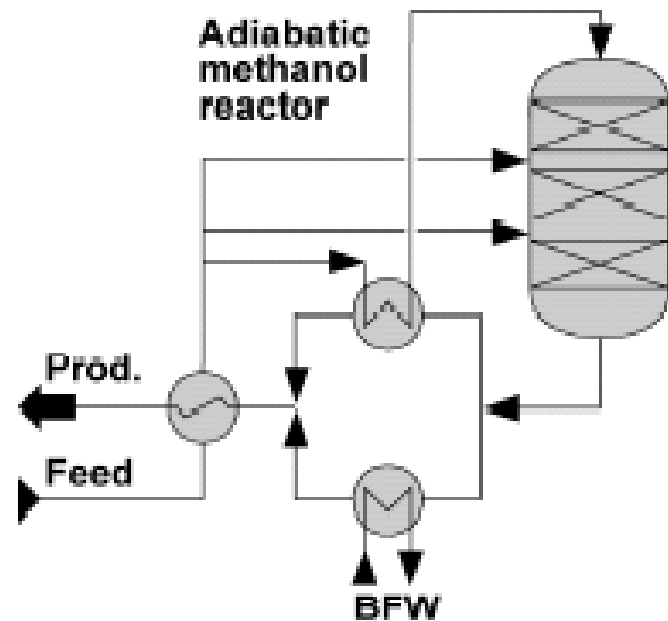

The axial radial multi-bed adiabatic quench is a low cost reactor concept. It is normally used for plants which require no steam in synthesis units, due to the fact, that surplus steam is produced during syngas generation (for instance steam reforming). Uhde can offer the ARC (Axial Radial Concept) technology licensed by Methanol Casale, Switzerland.

Methanol synthesis slurry process

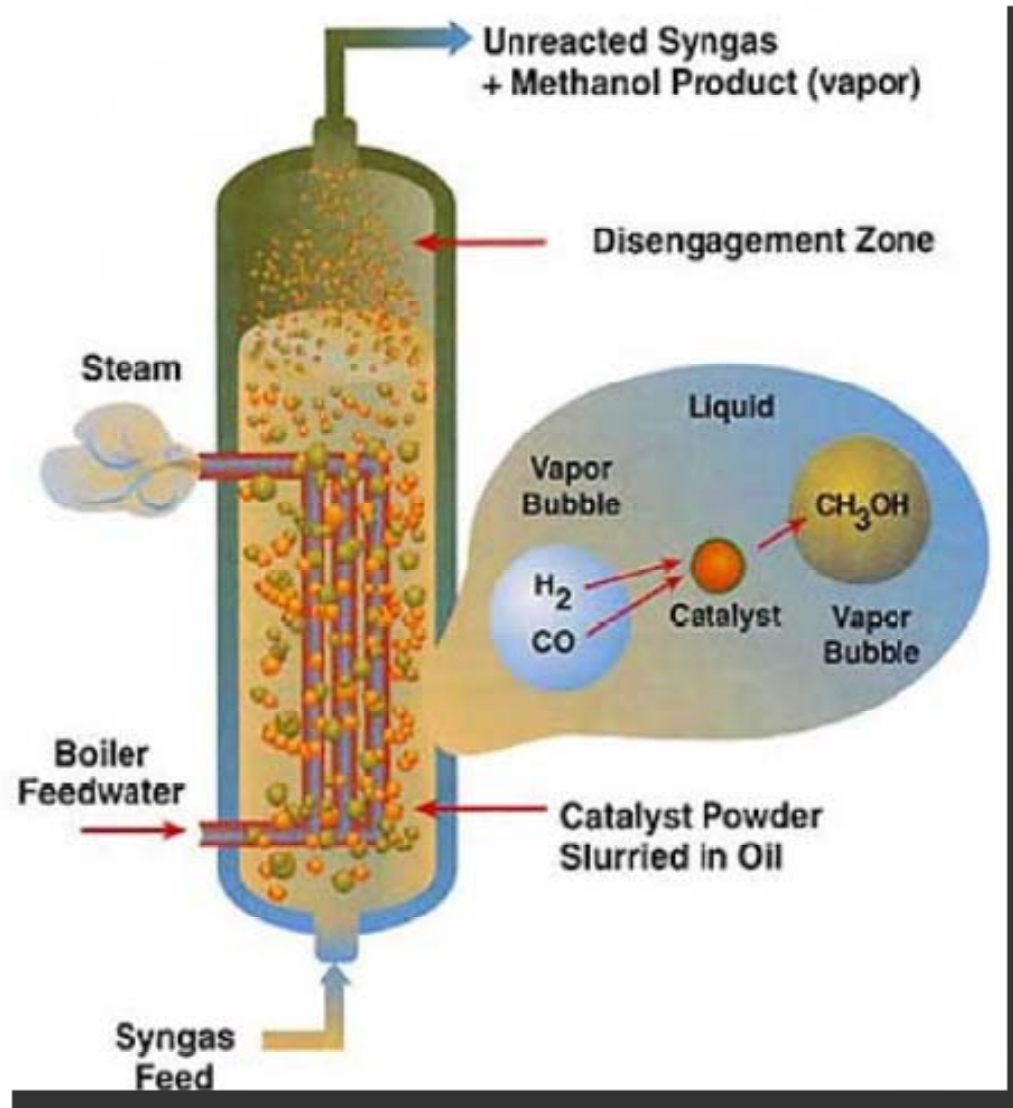

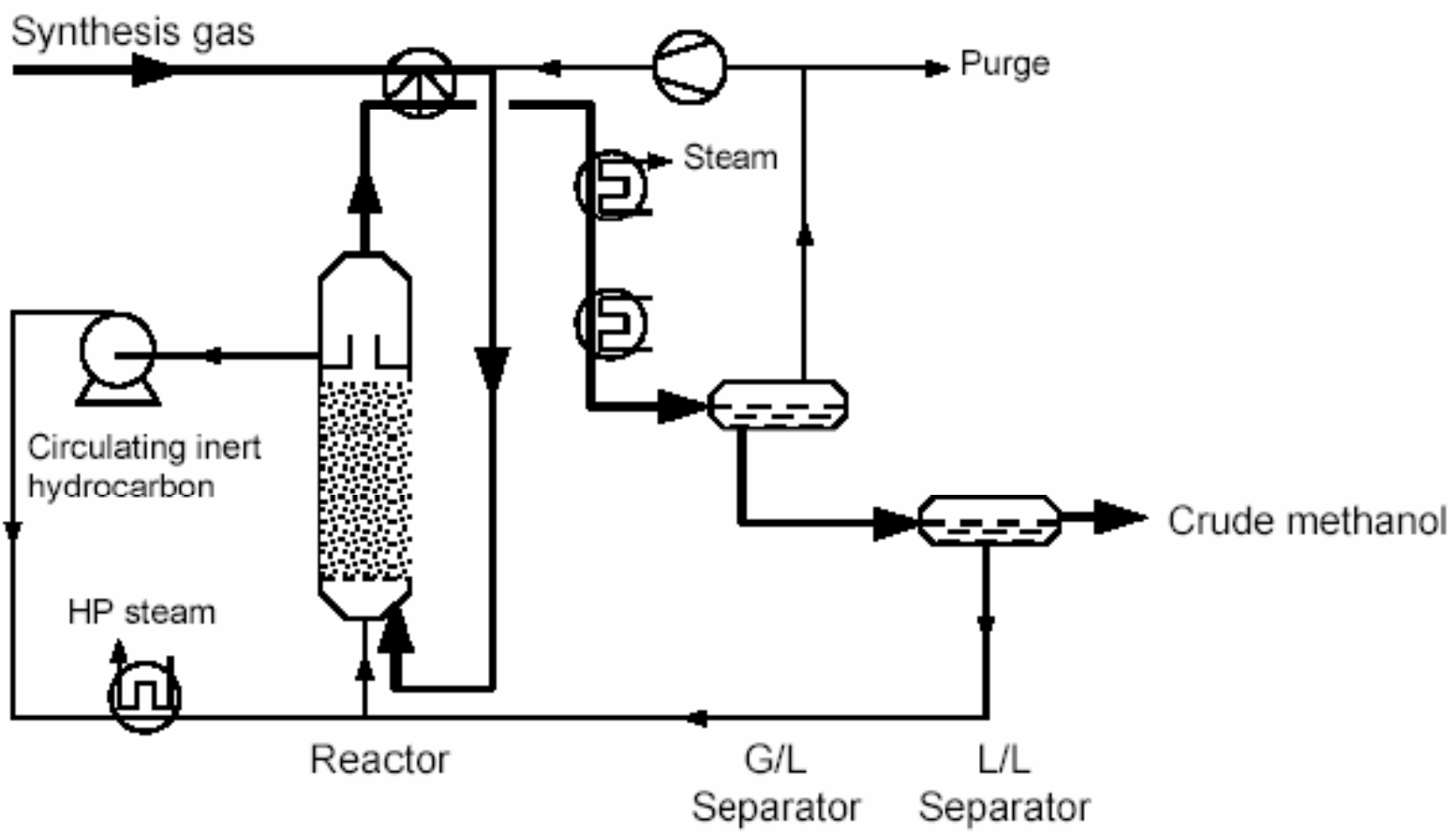

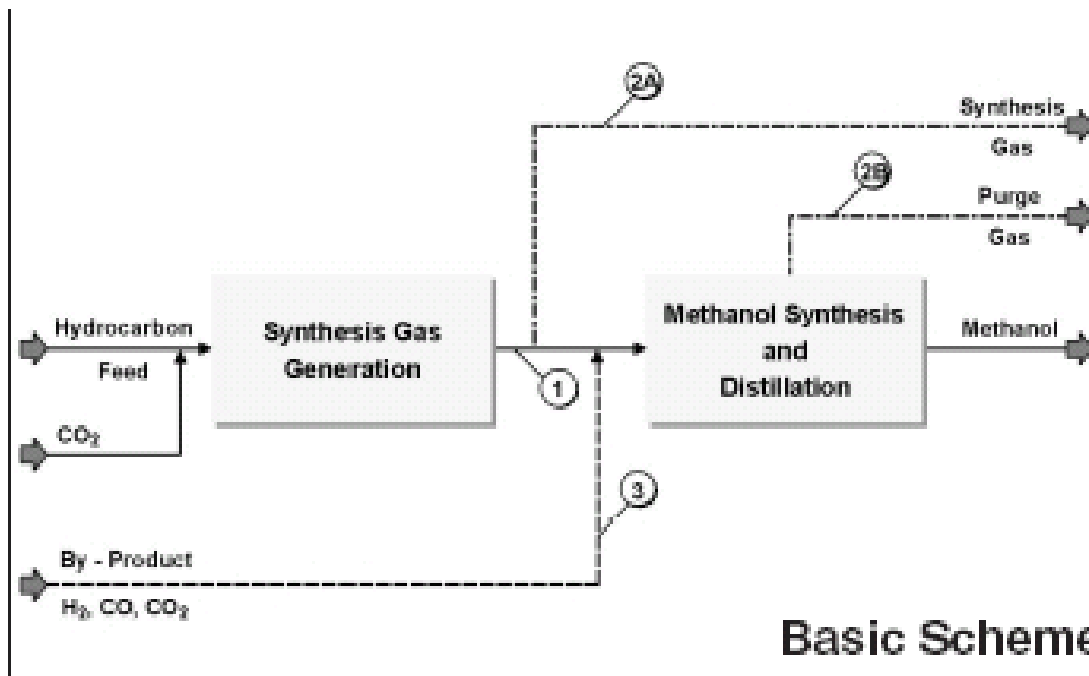

Basic Scheme 1: Routes producing syngas dedicated solely to methanol production

Basic Scheme 2: Routes producing syngas for methanol production as well as syngas and/or other by-products for other consumers in one train

Basic Scheme 3: Routes importing methanol syngas from by-product gases available from already existing sources

Tandem

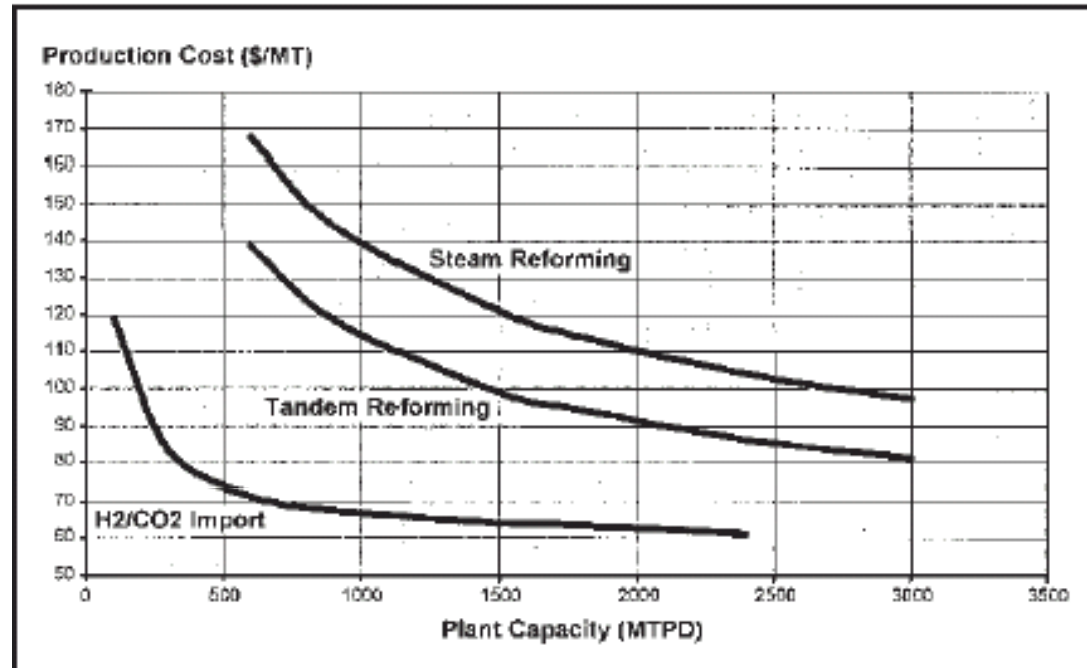

Methanol as base chemical

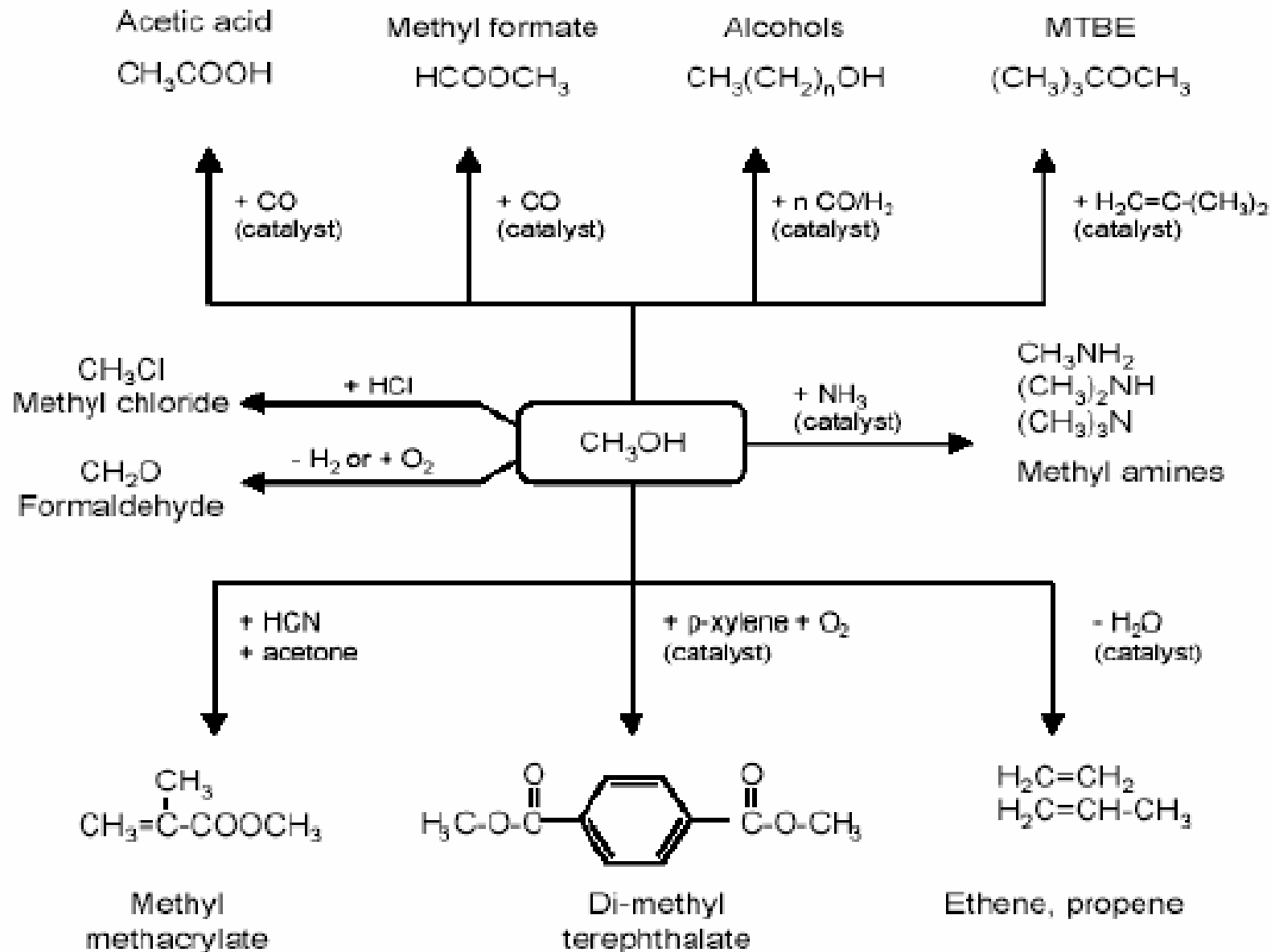

Natural Gas

Coal

Biomass



Diesel
Alternative



LPG



Power
Production



Chemical
Intermediate



DME – a simple molecule

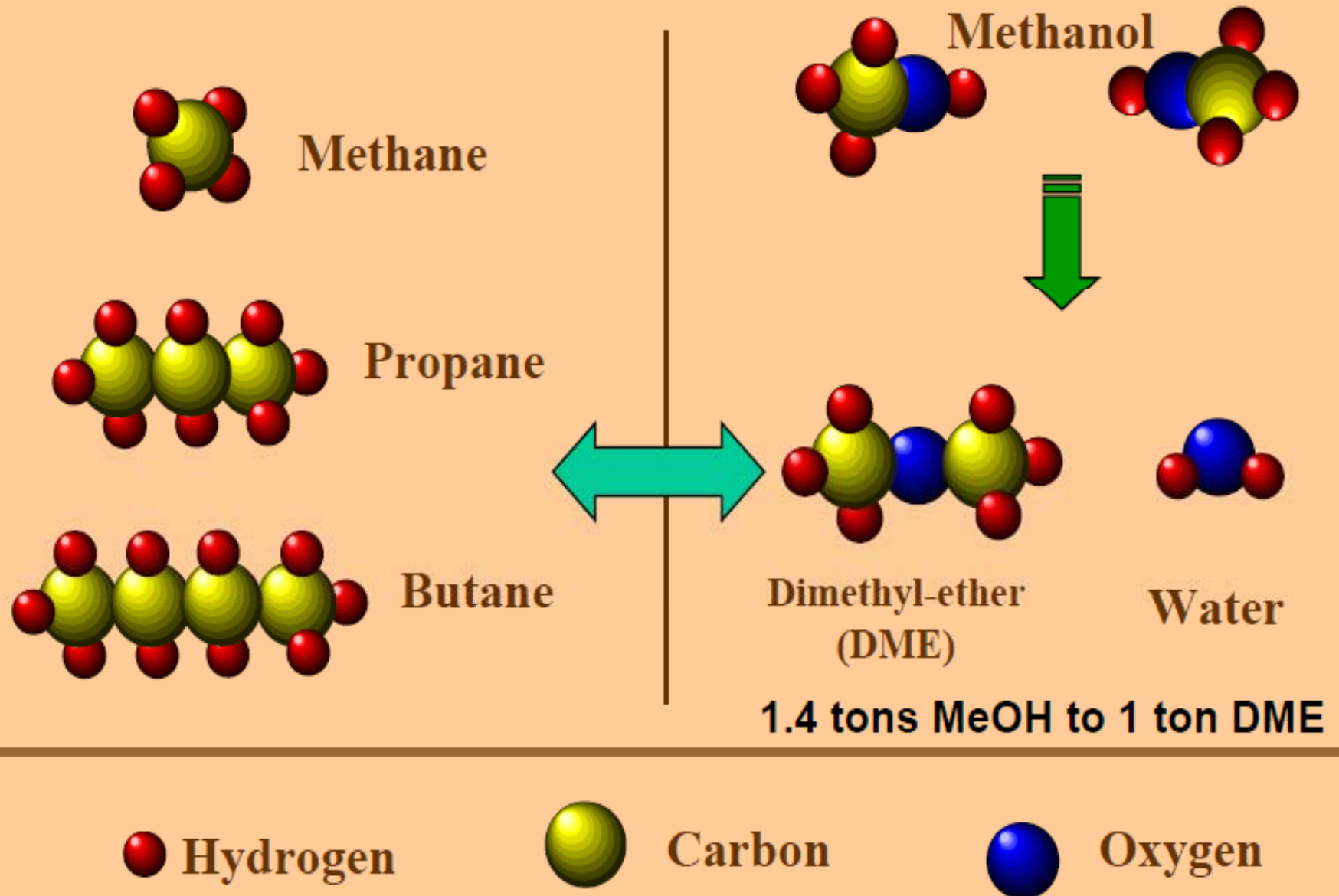

Combustion & Fuel Injection Relevant Properties of DME and Diesel

	DME	Diesel
Chemical Structure	$\text{CH}_3\text{-O-CH}_3$	$\text{C}_{15}\text{H}_{28}$
Liquid Density @ 40°C [kg/m ³]	634	840
Lower Calorific Value [MJ/kg]	28.4	42.7
Cetane No.	~65	40-50
Viscosity [Cst]	<0.2	~3
Boiling Point @ atm. Press. [°C]	-25	180-370

DME as Diesel Alternative

"DME is our preferred long term fuel, and under evaluation." Volvo Group (2005)

- Performs in conventional diesel engines with modified fuel injection system
 - High cetane
 - Quiet combustion
- Clean-burning: substantially lower emissions than diesel
 - Completely SOOTLESS (No smoke or particulates)
 - 100% SO_x reduction
- Challenges
 - Poor compatibility with polymers: fluorine based polymers can be used
 - Lower lubricity requires lubricating agent
 - Lower viscosity can cause leakage
 - Requires LPG-like distribution system
 - Government regulations



Strategic plan

FY	2002	2005	2010	2015	2020
Development Stage	Prototype Vehicles	Vehicle Test on Road	Fleet Test	Practical Use	Widespread Use

Fleet test plan in Japan



Test DME truck

Periodical vehicle emission test in NTSEL



DME manufacturing / supply station



DME tank truck



National Project of City Bus Fuelled with DME



DME in Iran

World's First Large-Scale DME Plant

- **Production capacity: 800,000 T/yr**
- **Owner: Zagros Petrochemical Co.**
- **Location: Bandar Assalouyeh/ Pars Special Economic/Energy Zone**
- **Licensors: NPC-RT and Haldor Topsoe AS**
- **Feed: ASTM Grade AA Methanol**
- **Technology: methanol dehydration, fixed-bed reactor**
- **Product purity (wt%) – above 99%**
- **Primary market: LPG substitute in Iran and Region**
- **Current Project Status:**
 - **EPC company selected**
 - **First production in 2008**

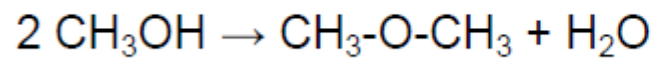
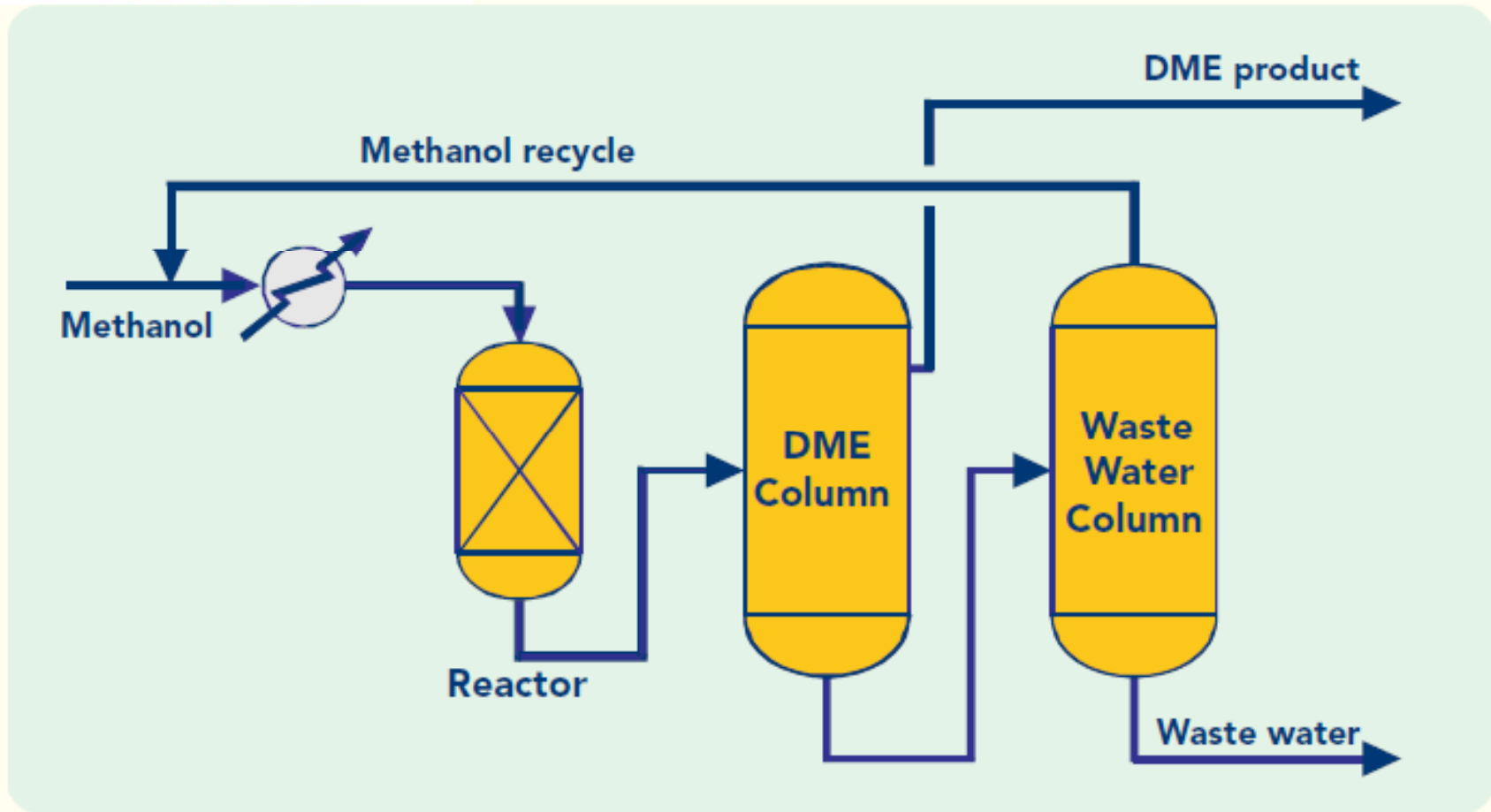

$$- \Delta H_{298} = 23.4 \text{ kJ/mol}$$

Operative conditions for DME

- Feed methanol is fed to a DME reactor after vaporization.
- The synthesis pressure is 1.0 - 2.0 MPa.
- The inlet temperature is 220 - 250 °C and the outlet is 300 - 350 °C.
- Methanol one pass conversion to DME is 70 – 85 % in the reactor.

HALDOR TOPSØE



CATALYSING YOUR BUSINESS

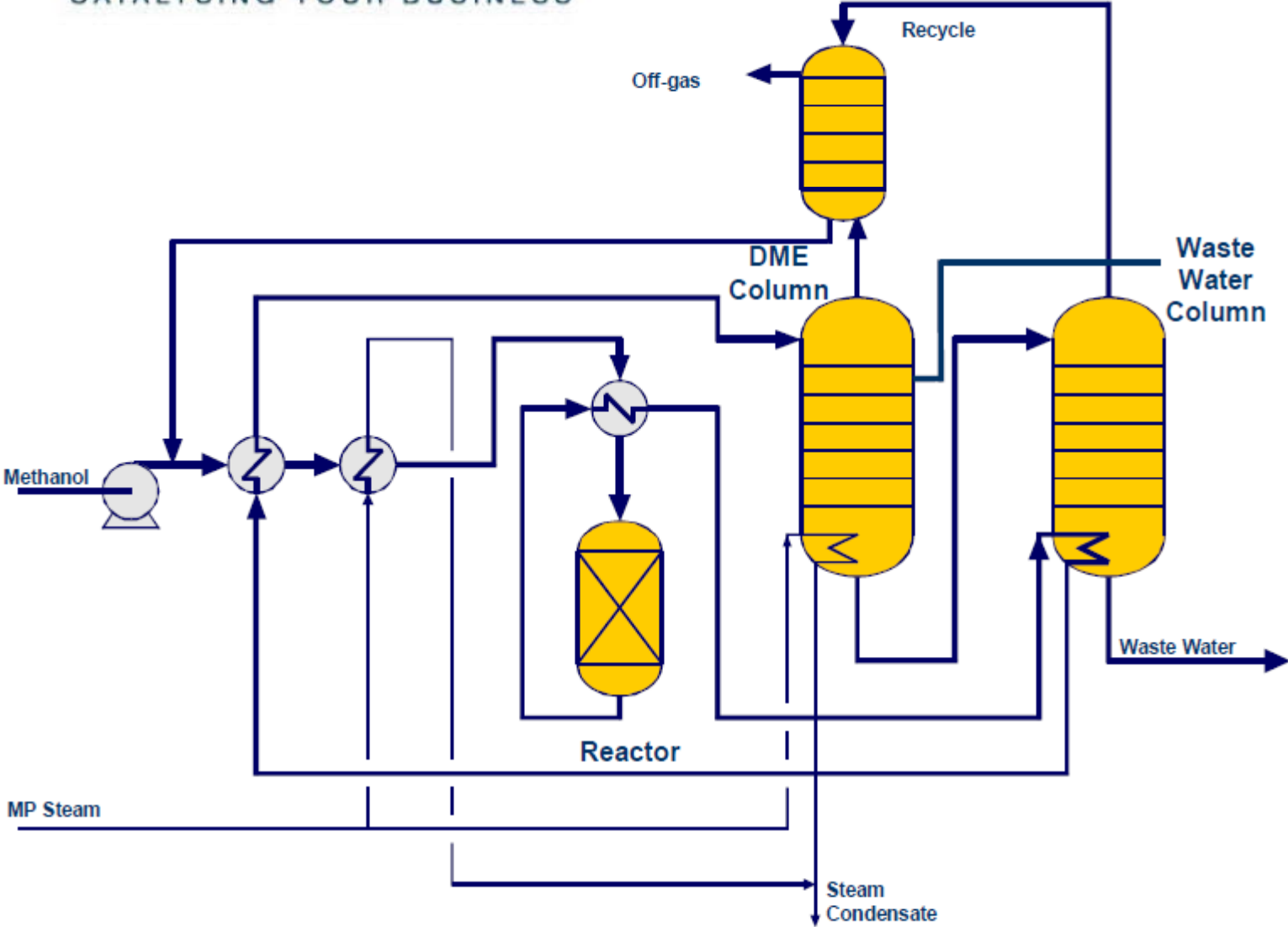



alumina

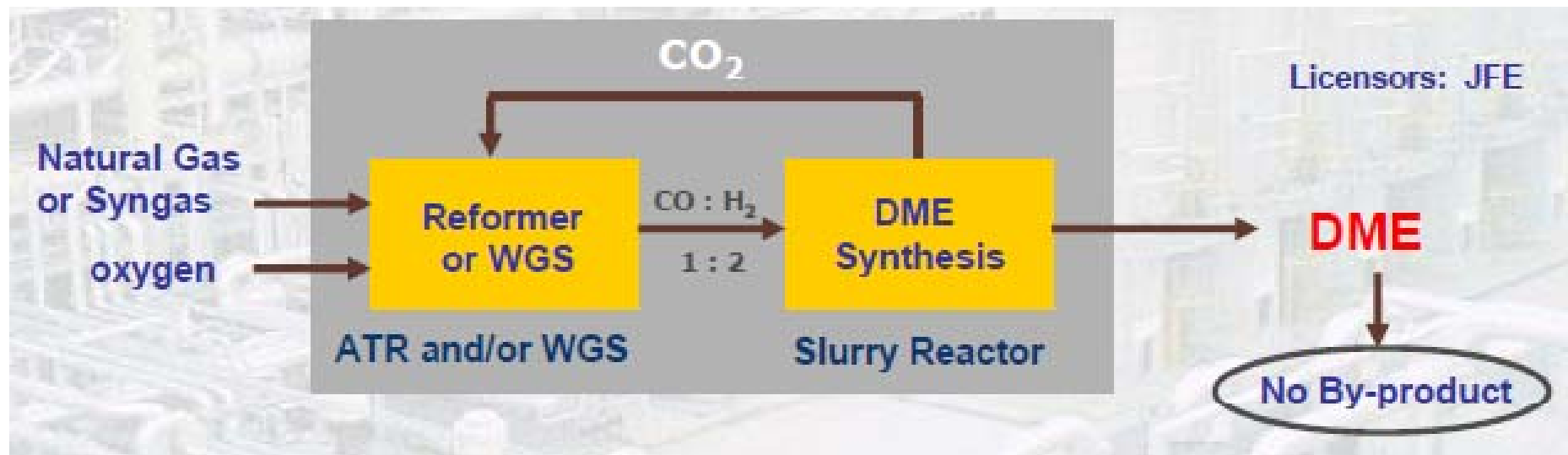

100 MTPD demo unit

- SU December 2003
- 346 day runtime
- 19,520 ton DME

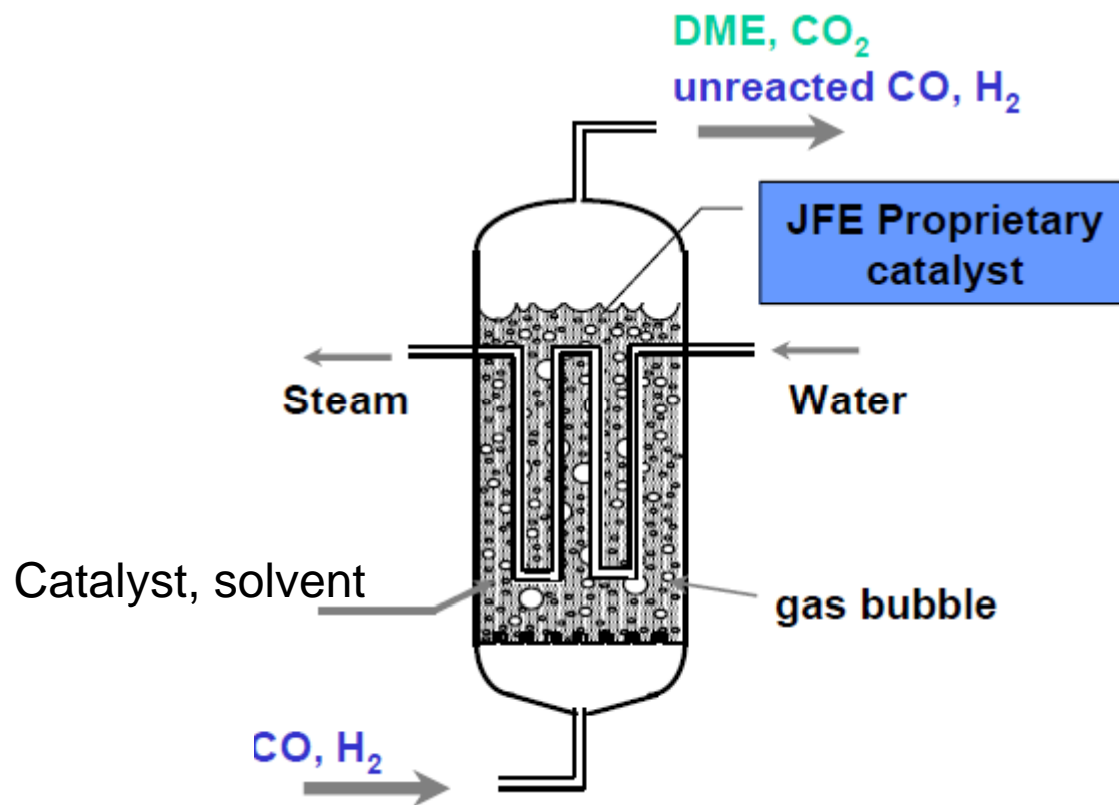

Pro

- Good temperature control
- No diffusion limitation
- Rapid load response
- In-line catalyst replacement

Con

- Complicated reactor layout (3 phases)
- Small catalyst loading fraction
- Catalyst attrition & distribution

Biorefinery R&D Focus: Remove Technical Barriers

